

IMSTM



intelligent motion systems, inc.

Excellence in MotionTM



OPERATING INSTRUCTIONS



The information in this book has been carefully checked and is believed to be accurate; however, no responsibility is assumed for inaccuracies.

*Intelligent Motion Systems, Inc., reserves the right to make changes without further notice to any products herein to improve reliability, function or design. Intelligent Motion Systems, Inc., does not assume any liability arising out of the application or use of any product or circuit described herein; neither does it convey any license under its patent rights of others. Intelligent Motion Systems and **IMS**[™] are trademarks of Intelligent Motion Systems, Inc.*

Intelligent Motion Systems, Inc.'s general policy does not recommend the use of its products in life support or aircraft applications wherein a failure or malfunction of the product may directly threaten life or injury. Per Intelligent Motion Systems, Inc.'s terms and conditions of sales, the user of Intelligent Motion Systems, Inc., products in life support or aircraft applications assumes all risks of such use and indemnifies Intelligent Motion Systems, Inc., against all damages.

*MDrive Operating Instructions
Revision 02.07.2002*

©1998-2002 by Intelligent Motion Systems, Inc.
All Rights Reserved

Table of Contents

Notes and Warnings	3
IMPORTANT! READ THIS FIRST!	3
The Product Manual	3

PART 1: General Connection and Configuration

Section 1.1: The MDrive Integral Motor+Driver	7
Section Overview	7
Introduction to the Microstepping MDrive	7
Features and Benefits of the Microstepping MDrive	8
Introduction to the Speed Control MDrive	9
Features and Benefits of the MDrive Speed Control	10
Section 1.2: Interfacing The Microstepping MDrive	11
Section Overview	11
Layout and Interface Guidelines	11
Interfacing Power and Logic Inputs (Connector P1)	12
Interfacing the MDrive SPI Interface (Connector P2)	17
Minimum Required Connections	18
Section 1.3: Interfacing An Encoder	19
Section Overview	19
Factory-Mounted Encoder	19
Section 1.4: Configuring The Microstepping MDrive	22
Section Overview	22
The IMS Motor Interface	22
Configuration Parameters Explained	23
Timing Notes	24
Configuring the MDrive Using SPI	24
SPI Commands	25
Section 1.5: Interfacing The Variable Speed Control MDrive	27
Section Overview	27
Layout and Interface Guidelines	27
Interfacing Power and Speed Control Inputs (Connector P1)	28
Interfacing the MDrive SPI Interface (Connector P2)	31
Minimum Required Connections	32
Section 1.6: Configuring The MDrive Variable Speed Control	33
Configuration Parameters Explained	34
Setting the Configuration Parameters	37

PART 2: MDrive17 Hardware Specifications

Section 2.1: MDrive17 Power & Thermal Requirements	40
Power Supply Requirements	40
Thermal Specifications	40
Section 2.2: Rotary MDrive17 Specifications	41
Section Overview	41
Mechanical Specifications	41
Motor Specifications	42
Electrical Specifications	44
Section 2.3: Linear MDrive17 Specifications	45
Section Overview	45
Mechanical Specifications	45
Motor Specifications (Linear)	45

PART 3: MDrive23 Hardware Specifications

Section 3.1: MDrive23 Power & Thermal Requirements	48
Power Supply Requirements	48
Thermal Specifications	48
Section 3.2: Rotary MDrive23 Specifications	49
Section Overview	49
Mechanical Specifications	49
Motor Specifications	50
Electrical Specifications	52
Section 3.3: Linear MDrive23 Specifications	53
Section Overview	53
Mechanical Specifications	53
Motor Specifications (Linear)	53

List of Figures

Figure 1.2.1	Microstepping MDrive Block Diagram	12
Figure 1.2.2	Connector P1 Pin Configuration for the Microstepping MDrive	12
Figure 1.2.3	Opto-Coupler Inputs	13
Figure 1.2.4	Open Collector Interface	15
Figure 1.2.5	TTL Interface	16
Figure 1.2.6	Switch Interface	16
Figure 1.2.7	SPI Interface Wiring and Connections	17
Figure 1.2.8	Minimum Required Connections	18
Figure 1.3.1	Encoder Connections	20
Figure 1.4.1	MDrive Configuration Utility Screen	22
Figure 1.4.2	SPI Timing Diagram	26
Figure 1.5.1	Variable Speed Control MDrive Block Diagram	28
Figure 1.5.2	P1 Pin Configuration for the MDrive Variable Speed Control	28
Figure 1.5.3	Interfacing the MDrive Speed Control using Switches and a Potentiometer	29
Figure 1.5.4	Interfacing the MDrive Speed Control using a 4 -20 mA Analog Output	29
Figure 1.5.5	SPI Interface Wiring and Connections	31
Figure 1.5.6	Minimum Required Connections	32
Figure 1.6.1	Speed Control Configuration Utility Screen	33
Figure 1.6.2	Speed Control Configuration Utility Screen	37
Figure 1.6.3	Initialization Mode	38
Figure 2.2.1	Rotary MDrive17 Mechanical Specifications	41
Figure 2.2.2	Interface Options	42
Figure 2.2.3	Rotary MDrive 1713 Speed/Torque Data	43
Figure 2.2.4	Rotary MDrive 1715 Speed/Torque Data	43
Figure 2.2.5	Rotary MDrive 1719 Speed/Torque Data	44
Figure 2.3.1	Linear Actuator MDrive17 Mechanical Specifications	45
Figure 2.3.2	Force/Speed Curve - 24VDC	46
Figure 2.3.3	Force/Speed Curve - 45VDC	46
Figure 3.2.1	Rotary MDrive23 Mechanical Specifications	49
Figure 3.2.2	Interface Options	50
Figure 3.2.3	Rotary MDrive 2218 Speed/Torque Data	51
Figure 3.2.4	Rotary MDrive 2222 Speed/Torque Data	51
Figure 3.2.5	Rotary MDrive 2231 Speed/Torque Data	52
Figure 3.3.1	Linear Actuator MDrive23 Mechanical Specifications	53
Figure 3.3.2	Force/Speed Curve - 24VDC	54
Figure 3.3.3	Force/Speed Curve - 45VDC	54
Figure 3.3.3	Force/Speed Curve - 75VDC	55

List of Tables

Table 1.2.1	P1 Pin Descriptions for the Microstepping MDrive	12
Table 1.2.2	Microstepping MDrive Logic Input Electrical Characteristics	13
Table 1.2.3	Logic Input Timing	15
Table 1.2.4	Recommended Input Current Limiting Resistor Values	16
Table 1.2.5	P2 Pin Assignment and Description	17
Table 1.3.1	Single End Encoder Pin Configuration	19
Table 1.3.2	Differential Encoder Pin Configuration	20
Table 1.4.1	Setup Parameters	23
Table 1.4.2	Microstep Resolution Settings	24
Table 1.4.3	SPI Command Summary	25
Table 1.5.1	P1 Pin Description for the MDrive Variable Speed Control	28
Table 1.5.2	P2 Pin Assignment and Description	30
Table 1.6.1	MDrive Parameter Summary	34
Table 1.6.2	RANGE Parameter Values	35
Table 1.6.3	MSEL Parameter Values	36
Table 2.1.1	Recommended Power Supply Specifications	40
Table 2.2.1	Rotary MDrive 1713 Motor Specifications	42
Table 2.2.2	Rotary MDrive 1715 Motor Specifications	43
Table 2.2.3	Rotary MDrive 1719 Motor Specifications	44
Table 2.2.4	Electrical Specifications	44
Table 2.3.1	Linear Actuator MDrive 17 Motor Specifications	45
Table 2.3.2	ACME Screws for the MDrive17 Linear Actuator	46
Table 3.1.1	Recommended Power Supply Specifications	48
Table 3.2.1	Rotary MDrive 2218 Motor Specifications	50
Table 3.2.2	Rotary MDrive 2222 Motor Specifications	51
Table 3.2.3	Rotary MDrive 2231 Motor Specifications	52
Table 3.2.4	Electrical Specifications	52
Table 3.3.1	Linear Actuator MDrive23 Motor Specifications	53
Table 3.3.2	ACME Screws for the MDrive23 Linear Actuator	55

IMPORTANT! READ THIS FIRST!

The Product Manual

Using This Manual

This manual is divided into three parts:

Part 1 is **General Information**, which covers details common to the entire MDrive product line such as operational theory, connection and interface instructions, and troubleshooting.

Part 2 is **MDrive17 Hardware Reference**. This part contains sections with information specific to each individual MDrive17 version. Here you will find details such as mechanical, electrical and thermal specifications and other product specific details.

Part 3 is **MDrive23 Hardware Reference**. This part contains sections with information specific to each individual MDrive23 version. Here you will find details such as mechanical, electrical and thermal specifications and other product specific details.

Do not attempt to connect or use your MDrive without first consulting the section specific to the type of MDrive you purchased!

As this document covers all of the variations of the MDrive, please use the chart on the following page to help guide you through the sections of this manual relevant to the version of the MDrive you purchased.

Notes and Warnings



WARNING! The MDrive has components which are sensitive to Electrostatic Discharge (ESD). All handling should be done at an ESD protected workstation.



WARNING! Hazardous voltage levels may be present if using an open frame power supply to power your MDrive product.



WARNING! Ensure that the power supply output voltage does not exceed the maximum input voltage of the MDrive product that you are using!

USING THE MDRIVE PRODUCT MANUAL

Microstepping MDrive Variants

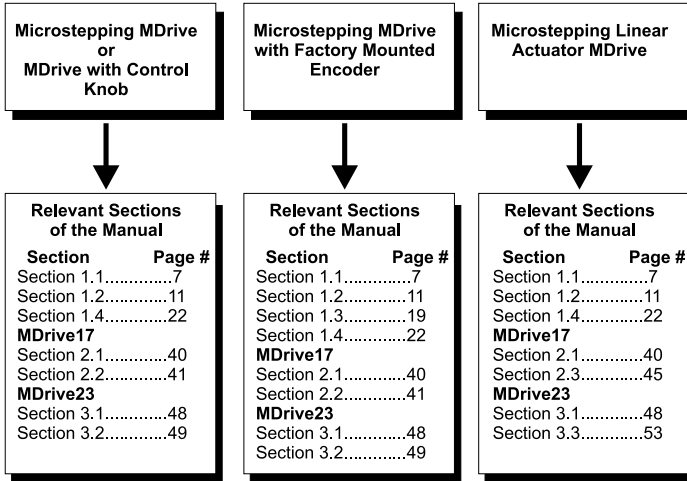

Variable Speed Control MDrive Variants

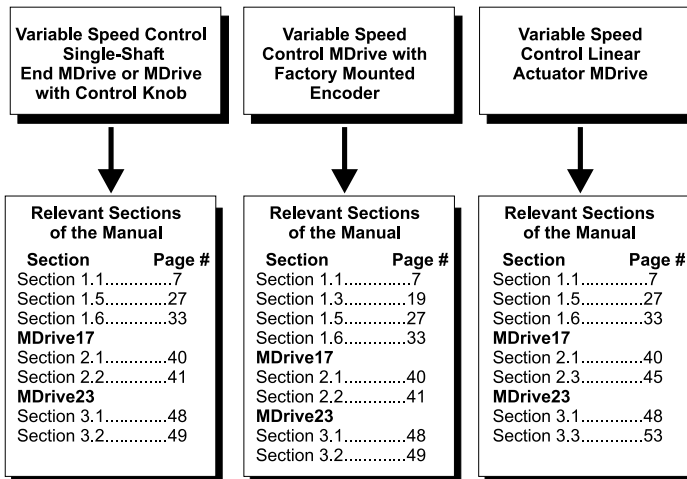

PART I

MDRIVE INTEGRATED MOTOR AND ELECTRONICS

General Information



Intentionally Left Blank

SECTION 1.1

The MDrive Integral Motor+Driver

Section Overview

The purpose of this section is to introduce the user to the MDrive integrated high torque motor and microstepping driver. Covered are:

- Introduction to the Microstepping MDrive
- Microstepping MDrive Features and Benefits
- Introduction to the Speed Control MDrive
- Speed Control MDrive Features and Benefits

Introduction to the Microstepping MDrive

The MDrive high-torque Integrated Motor and Driver is ideal for designers who want the simplicity of a motor with on-board electronics, but without the expense of an indexer on each axis. The low cost MDrive puts the system designer in the driver's seat to decide the best method of control. The Drive's integrated electronics eliminates the need to run the motor cabling through the machine, reducing the potential for problems due to electrical noise.

The MDrive uses a NEMA 17 or NEMA 23 1.8° motor combined with a microstepping drive, and accepts up to 14 resolution settings from 1/2 to 256 microsteps per step. Setup parameters include Microstep Resolution, Run and Hold currents, and can be changed on-the-fly or downloaded and stored in non-volatile memory with the use of a simple user interface program which is provided, eliminating the need for external switches or resistors. Parameters are changed via an SPI (Serial Peripheral Interface) port located on connector P2. This port connects to the printer port on your PC. Operating voltage for the MDrive17 ranges from +12 to +48 VDC. The MDrive23 is available in two voltage ranges, either +12 to +48 or +24 to +75 VDC.

The versatile, compact MDrive is available in multiple configurations to fit various system needs including a single shaft stand-alone device, a rotary motor with optical encoder, an Acme screw linear actuator, or with an optional rear knob for hand operation of the motor. The rotary MDrive is available in three different stack lengths: 13, 15 & 19 for the MDrive17; and 18, 22 & 31 for the MDrive23. Interface connections are accomplished using either a 7 position terminal block or optional 12" (30.5cm) flying leads.

The MDrive is a small, powerful and inexpensive solution that will reduce system cost, design and assembly time for a large range of stepping motor applications.

IMS Motor Interface

The IMS Motor Interface is the software utility used to set the standard MDrive's parameters. This program is an easy to install and use graphical user interface (GUI) for configuring the MDrive from the parallel port on your computer. This utility is included on a CD that ships with the product, or it may be downloaded at www.imshome.com. An optional parameter setup cable is also available for ease of connecting and configuring the MDrive. Purchase of this cable is recommended with the first order as it includes built-in logic level shifting circuitry to make the MDrive's SPI port compatible with all PC LPT (printer) port voltage levels.

Configuration Utility features include:

- Easy installation.
- Automatic communication configuration.
- Will not set out-of-range values.
- Tool-tips display valid range setting for each option.
- Ease of use via single screen interface.

Features and Benefits of the Microstepping MDrive

- Integrated Microstepping Drive/NEMA 17 or 23 Motor
 - +12 to +48 VDC (MD17)/+12 to +48 or +24 to +75 VDC (MD23) Input Voltage
 - Low Cost
 - Extremely Compact
 - Optically Isolated Logic Inputs
 - Automatic Current Reduction
 - Configurable:
 - Motor Run/Hold Current
 - Microstep Resolution to 256 Microsteps/Step
 - Available Configurations:
 - Single Shaft*
 - Linear Actuator
 - Factory-Mounted Optical Encoder*
 - Double Shaft End with Knob For Manual Positioning*
 - Available in Three Stack Sizes*
 - Current and Resolution May Be Switched On-The-Fly
 - Single Supply
 - Interface Uses Pluggable Terminal Strip or 12" (30.5 cm) Flying Leads
 - Graphical User Interface (GUI) for Quick and Easy Parameter Setup
- *Rotary Motor Only

Introduction to the Speed Control MDrive

The MDrive Variable Speed Control offers the system designer low cost, intelligent velocity control integrated with a NEMA 17 or NEMA 23 enhanced torque stepping motor and a +12 to +48 (MD17 and MD23-4) or +24 to +75 (MD23-7) volt microstepping drive.

The MDrive Variable Speed Control features a digital oscillator for accurate velocity control with an output frequency of up to 100 kilohertz. Output frequency will vary with the voltage level on the speed control input. The speed control input can be adjusted by using one of the following methods:

- 10k Potentiometer.
- 0 to +5V applied directly to the input.
- 15 - 25kHz (0 to 100% duty cycle) PWM applied to the input.
- 4 - 20mA applied to input.

There are two basic modes of operation: bidirectional and unidirectional. In bidirectional mode, both speed and direction are controlled by the analog speed control input. In unidirectional mode, only velocity is controlled by the speed control input; direction is controlled by a separate digital input.

The MDrive Variable Speed Control has 12 setup parameters which are configured by using the included Configuration Utility. These enable the user to configure all of the operational parameters of the MDrive which are stored in non-volatile memory.

The versatile, compact MDrive Variable Speed Control is available in multiple configurations to fit various system needs. These options include: a single shaft stand-alone device, a rotary motor with optical encoder, control knob, or an Acme screw linear actuator. The rotary MDrive Speed Control is also available in three different stack lengths: 13, 15 and 19 for the MD17 and 18, 22 & 31 for the MD23. Interface connections are accomplished using either a 7 position terminal block or optional 12" (30.5cm) flying leads.

Speed Control Interface

The IMS Speed Control Interface is an easy to install and use graphical user interface (GUI) for configuring the MDrive from the parallel port on your computer. It is required for configuring your MDrive Variable Speed Control and is included on a CD with the product, or it may be downloaded at www.imshome.com.

Speed Control Interface features include:

- Easy installation.
- Automatic communication configuration.
- Will not set out-of-range values.
- Tool-tips display valid range setting for each option.
- Ease of use via single screen interface.

Features and Benefits of the MDrive Speed Control

- Integrated Speed Control, Driver and NEMA17 or 23 Motor
- +12 to +48 (MDO17 and MDO23-4) or +24 to +75 VDC (MDO23-7) Input Voltage
- Digital Oscillator for Accurate Speed Control
- Low Cost
- Extremely Compact
- Available Configurations:
 - Single Shaft*
 - Linear Actuator
 - Factory-Mounted Optical Encoder*
 - Double Shaft End with Knob For Manual Positioning*
- Available in Three Stack Sizes*
- Electronically Configurable (Eliminates Potentiometers):
 - Motor Run/Hold Current
 - Acceleration/Deceleration
 - Initial and Max Velocity
 - Microstep Resolution to 256 Microsteps/Step
- 2 Modes of Operation: Bidirectional or Unidirectional
- 0 to +5 VDC, 4 - 20mA or 15 - 25kHz PWM Speed Control Input with programmable center point
- Single Supply
- Interface Uses Pluggable Terminal Strip or Optional 12" (30.5 cm) Flying Leads
- Graphical User Interface (GUI) for Quick and Easy Parameter Setup

*Rotary Motor Only

SECTION 1.2

Interfacing The Microstepping MDrive

Section Overview

This section will acquaint the user with connecting and using the microstepping MDrive products. If your MDrive is equipped with a factory mounted encoder, also refer to Section 1.3: Interfacing an Encoder. Covered in this section are:

- Layout and Interface Guidelines
- Interfacing Power and Logic Inputs (Connector P1)
- Interfacing the SPI Interface (Connector P2)

Layout and Interface Guidelines

Logic level cables must not run parallel to power cables. Power cables will introduce noise into the logic level cables and make your system unreliable.

Logic level cables must be shielded to reduce the chance of EMI induced noise. The shield needs to be grounded at the signal source to AC ground. The other end of the shield must not be tied to anything, but allowed to float. This allows the shield to act as a drain.

Power supply leads to the driver need to be twisted. If more than one driver is to be connected to the same power supply, run separate power and ground leads from the supply to each driver.

Recommended Wiring

The following wiring/cabling is recommended for use with the MDrive:

Power

Belden Part# 9740 or equivalent 18 Gauge

Logic Wiring

Wire Size 20-22 AWG

General Practices

The following wire strip length is recommended:

Wire Strip Length 0.250" (6.0 mm)



WARNING! Do not connect or disconnect any wiring when power is applied!



WARNING! See Part II for power supply requirements for the MDrive17, Part III for the MDrive23.

Interfacing Power and Logic Inputs (Connector P1)

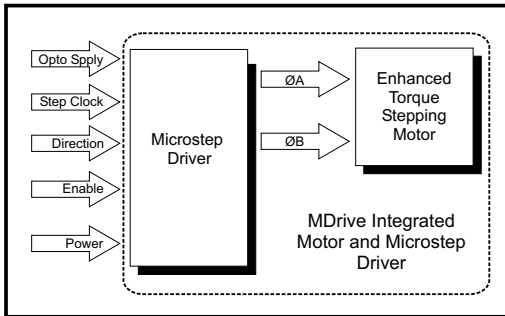

Figure 1.2.1: Microstepping MDrive Block Diagram

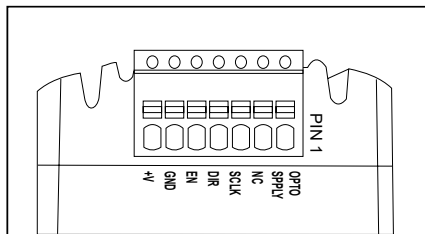

Figure 1.2.2: Connector P1 Pin Configuration for the Microstepping MDrive

MDrive Connector P1 Configuration			
PIN #	FLYING LEAD	FUNCTION	DETAILS
1	White	Opto Supply	This +5VDC input is used to supply power to the isolated logic inputs. A higher voltage may be used, but care must be taken to limit the current through the opto-coupler.
2	---	N/C	Not Connected
3	Orange	Step Clock Input	A positive going edge on this input advances the motor one increment. The size of the increment is dependant upon the Microstep Resolution setting.
4	Blue	CW/CCW Direction Input	This input is used to change the direction of the motor Logic HIGH state (open) = CW
5	Brown	Enable/Disable Input	This input is used to enable/disable the output section of the driver. When in a Logic HIGH state (open), the outputs are enabled. However, this input does not inhibit the step clock, therefore, the outputs will update by the number of clock pulses (if any) applied to the driver while it was disabled.
6	Black	Power Ground	Power Supply Ground (Return)
7	Red	+V	+12 to +48 VDC(MD17, MD23-4) / +24 to +75 VDC (MD23-7)

Table 1.2.1: P1 Pin Descriptions for the Microstepping MDrive

Interfacing the MDrive Logic Inputs

Logic Input Electrical Specifications

MDrive Logic Input Electrical Characteristics					
Specification	Test Condition	Min	Typ	Max	Unit
Input Forward Current	Step Clock and Direction		7.0	15	mA
Input Forward Voltage	Step Clock and Direction		1.4	1.7	V
Input Forward Current	Enable		5.0	9.4	mA
Input Forward Voltage	Enable		1.1	1.4	V
Input Reverse Breakdown Voltage	Isolated Inputs	5			V

Table 1.2.2: Microstepping MDrive Logic Input Electrical Characteristics

Optically Isolated Logic Inputs

The MDrive has 3 optically isolated logic inputs which are located on connector P1. These inputs are isolated to minimize or eliminate electrical noise coupled onto the drive control signals. Each input is internally pulled-up to the level of the optocoupler supply and may be connected to sinking outputs on a controller such as the IMS LYNX or a PLC. These inputs are:

- 1] Step Clock (P1:3)
- 2] Direction (P1:4)
- 3] Enable (P1:5)

Of these inputs only step clock and direction are required to operate the MDrive.

The schematic shown in Figure 1.2.3 illustrates the inputs.

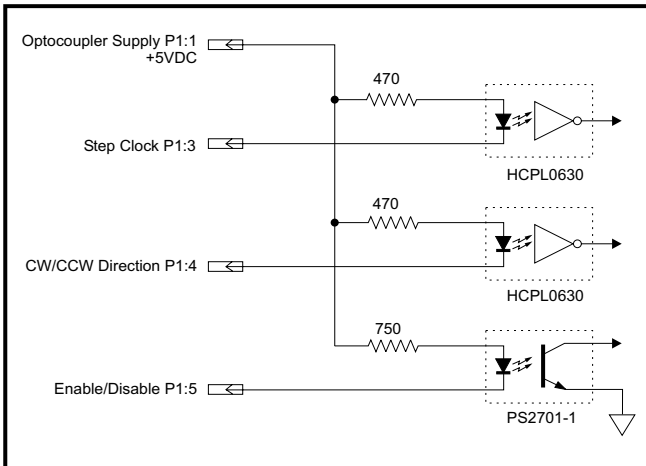

Figure 1.2.3: Opto-Coupler Inputs

Powering the Optocouplers

In order to maintain isolation, the optocouplers must be powered by an external power supply connected to P1:1, with the opto supply ground connected to the ground of the input control circuitry. The logic inputs are internally limited to allow for a +5VDC power supply.

A power supply in excess of +5 volts may be used, however a current limiting resistor **MUST** be placed in series with the input to limit the input forward current to the recommended 7 milliamps. At no time can the input forward current exceed 15 milliamps or damage may occur to the driver portion of the MDrive.

Isolated Logic Input Characteristics

Step Clock (P1:3)

The step clock input is where the motion clock from your control circuitry will be connected. The motor will advance one microstep in the plus or minus direction (based upon the state of the direction input) on the rising edge of each clock pulse. The size of this increment or decrement will depend on the microstep resolution setting.

Direction (P1:4)

The direction input controls the CW/CCW direction of the motor. A logic HIGH (default, unconnected) will cause the motor to rotate in the CW direction (seen while looking at the face of the motor). A logic LOW on the input will cause the motor to rotate in the CCW direction. This input is synchronized to the positive going edge of the Step Clock input.

Enable (P1:5)

This input can be used to enable or disable the driver output circuitry. When in a logic HIGH (default, unconnected) state the driver outputs will be enabled and step clock pulses will cause the motor to advance. When this input is pulled LOW, by means of a switch or sinking output, the driver output circuitry will be disabled. Please note that the internal sine/cosine position generator will continue to increment or decrement as long as step clock pulses are being received by the MDrive.

This input is asynchronous to any other input and may be changed at any time.



WARNING! The isolated logic inputs on the MDrive are internally limited to allow for an optocoupler supply voltage of +5 VDC. If using a higher voltage supply, a current limiting resistor must be placed in series with the input or damage will occur to the MDrive's input circuitry, rendering the drive inoperable.

Input Timing

The direction input and the microstep resolution inputs are internally synchronized to the positive going edge of the step clock input. When a step clock pulse goes HIGH, the state of the direction input and microstep resolution settings are latched. Any changes made to the direction and/or microstep resolution will occur on the rising edge of the step clock pulse following this change.

Run and Hold Current changes are updated immediately.

Table 1.2.4 lists the timing specifications.

MDrive Logic Input Timing		
Specification	Input	Time
Minimum Pulse Width	Step Clock	400 nS
Max. Frequency	Step Clock	2.5 MHz

Table 1.2.3: Logic Input Timing

Interface Options

Open Collector Interface

Figure 1.2.4 shows an open collector interface connected to the direction input (P1:3). This interface method may be used with any of the logic inputs. Remember that a current limiting resistor must be used in series with the input if an opto supply voltage greater than +5 volts is used. Refer to Table 1.2.5 for resistor values.

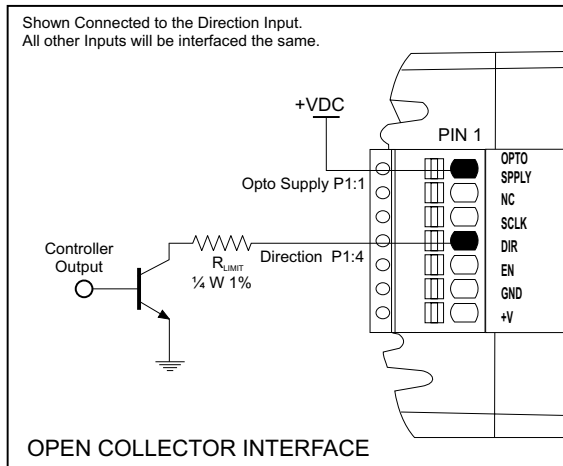

Figure 1.2.4: Open Collector Interface

TTL Interface

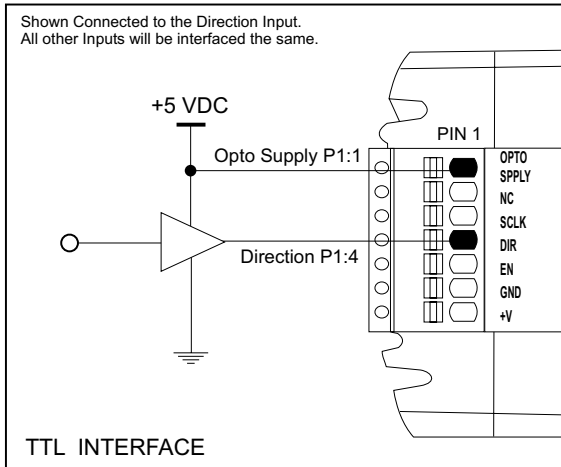

Figure 1.2.5: TTL Interface

Switch Interface

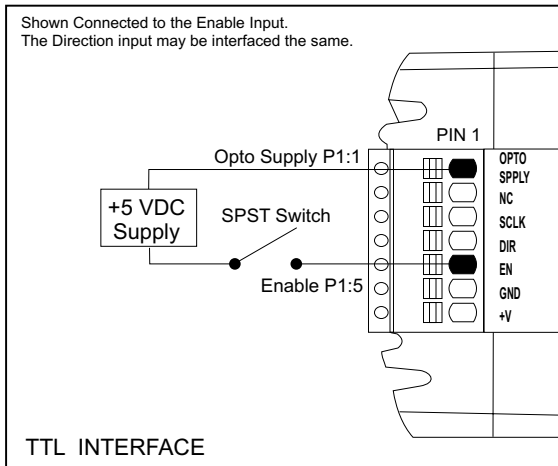

Figure 1.2.6: Switch Interface

Isolated Input Current Limiting Resistors		
Opto Supply (+VDC)	Resistor Value (Ohms 5%)	Resistor Value (Ohms 1%)
5	-	-
10	680	681
12	1000	1000
15	1300	1300
24	2700	2670

Table 1.2.4: Recommended Input Current Limiting Resistor Values

Interfacing the MDrive SPI Interface (Connector P2)

The SPI communications connector uses a 10 pin IDC header. The recommended method of connecting to this connector is the Parameter Setup Cable MD-CC100-000. In addition to offering ease of connection this cable features a built-in logic level shifter for computers that run on 3.3V output ports. This low-cost accessory eliminates the need of wiring the SPI interface.

MDrive Connector P2 (SPI Interface)		
Pin #	Function	Description
1	N/C	No Connect.
2	N/C	No Connect.
3	N/C	No Connect.
4	CS	Chip Select.
5	GND	Communications Ground.
6	+5VDC	+5 VDC Output (SEE WARNING BELOW!).
7	MOSI	Master Out/Slave In.
8	CLK	Clock.
9	N/C	No Connect.
10	MISO	Master In/Slave Out.

Table 1.2.5: P2 Pin Assignment and Description



WARNING! The +5VDC output on connector P2 is used for the setup cable **ONLY!** This output is not designed to power external devices!

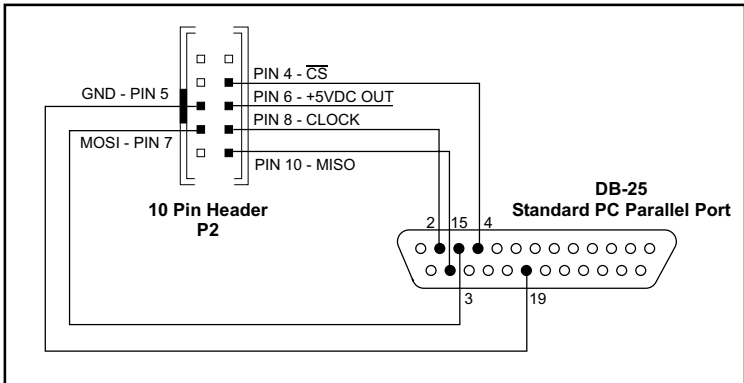

Figure 1.2.7: SPI Interface Wiring and Connections



NOTE: Should you choose to make your own parameter setup cable, be advised the 3.3V output parallel ports on some laptop PCs may not be sufficient to communicate with the device.

Minimum Required Connections

The connections shown in Figure 1.2.8 are the minimum required to operate the Microstepping MDrive.

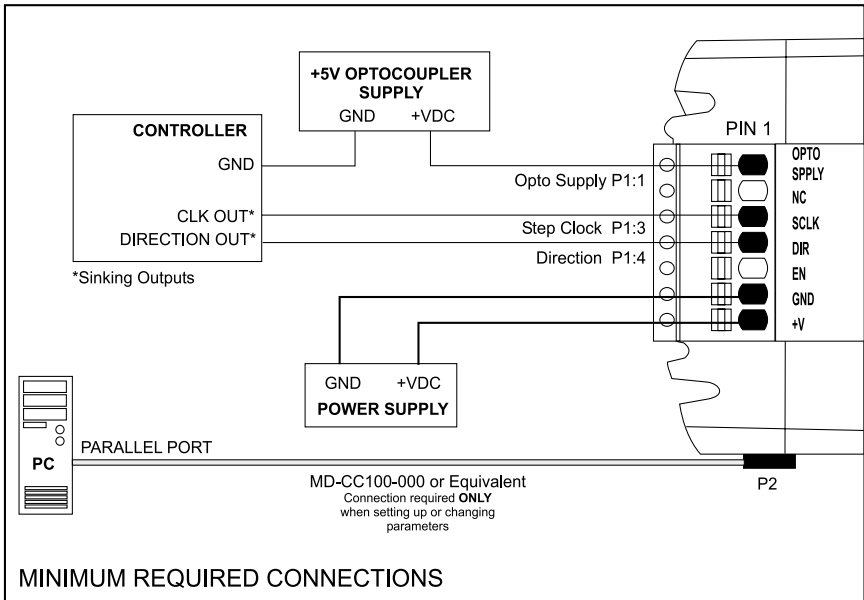

Figure 1.2.8: Minimum Required Connections

SECTION 1.3

Interfacing An Encoder

Section Overview

This section will cover interfacing the Factory Mounted Encoder version of both the Microstepping MDrive and the MDrive Variable Speed Control. Included are the pin configurations for both the single-end and differential models and the recommended cables and connectors.



Factory-Mounted Encoder

The MDrive is available with a factory-mounted optical encoder. Available line counts:

- 100
- 200
- 300
- 500

Encoders are available in both single-end and differential configurations. All encoders have an index mark.

Use of the encoder feedback feature of this product requires a controller such as an IMS LYNX or PLC.

The encoder has a 200kHz maximum output frequency.

Pin Configuration

The encoder has the following pin configurations:

Single End Encoder

MDrive Single End Encoder Configuration	
PIN #	FUNCTION
1	Ground
2	Index
3	Channel A
4	+5VDC Input
5	Channel B

Table 1.3.1: Single End Encoder Pin Configuration

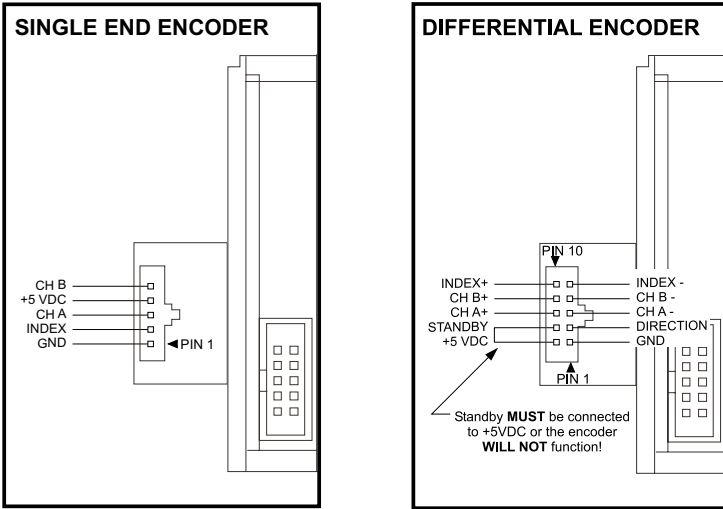

Figure 1.3.1: Encoder Connections

Differential Encoder

MDrive Differential Encoder Configuration	
PIN #	FUNCTION
1	Ground
2	+5VDC Input
3	Direction
4	Standby - (MUST be Tied to +5VDC Input!)
5	Channel A-
6	Channel A+
7	Channel B-
8	Channel B+
9	Index -
10	Index +

Table 1.3.2: Differential Encoder Pin Configuration



WARNING! The Standby- (Pin 4) on the differential encoder **MUST** be connected to +5VDC (Pin 2) or the encoder will not function!

Recommended Cables and Connectors

IMS recommends the following cables/connectors for use with the encoder.

Single End Encoder (ES) (10' Max. Cable Length)

Dupont/Berg

78211-005⁽¹⁾, 65039-032 (use either housing with Ultra-High Spring Force Mini PV terminals (48257-000), 22-36 AWG)

Molex/Waldom

50-57-9005 (2695 series) (use 16-02-1125 (2759 series) high pressure terminals, 22-30 AWG)

AMP

103975-4⁽³⁾

Differential Encoder (ED) (50' Max. Cable Length)

3M

89110-0101^(1,2), 89110-0001⁽²⁾

AMP

102398-3⁽³⁾, 87456-6, 102387-1⁽¹⁾, 11918-1, 746228-1^(1,2), 746290-1⁽²⁾

Amphenol

842-812-1022-118⁽²⁾, 842-812-1033-118^(1,2)

Dupont/Berg

65043-032, 71602-010^(1,2)

Robinson Nugent

IDS-C10NPK-TR⁽²⁾, IDS-C10PK-TR^(1,2)

Thomas & Betts

622-1000⁽²⁾, 622-1030^(1,2)

Molex/Waldom

22-55-2101

(1) Polarized; (2) IDC Ribbon Cable; (3) IDC (Ultra-High or High Spring Force terminals are recommended.)

SECTION 1.4

Configuring The Microstepping MDrive

Section Overview

This section is general to all MDrive versions with the exception of the Variable Speed Control version of the MDrive. Refer to Section 1.6 for details on the configuration utility for this product. This section will acquaint the user with the following:

- The MDrive Configuration Utility
- Configuration Parameters

The IMS Motor Interface

The IMS Motor Interface is an easy to install and use software program. Use of this utility is required in order to configure the MDrive. It is included on the CD that ships with the MDrive or is available for download at www.imshome.com. This utility features the following:

- Easy installation.
- Ease of use via single screen interface.
- Automatic communication configuration.
- Will not allow out-of-range values to be set.
- Tool-tips display valid range settings for each option.

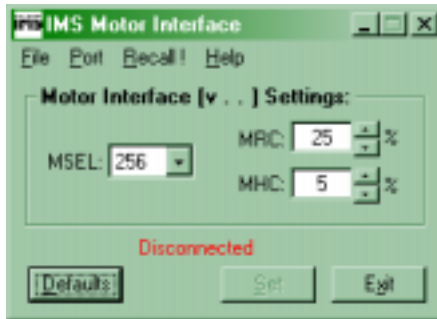

Figure 1.4.1: MDrive Configuration Utility Screen

Installation

To install and use the configuration utility you need a Pentium class or higher PC running Windows 95/98. If you are using Windows NT 4.0 (SP6 or greater) or Windows 2000 (SP1 or greater) use the NT version of this software. The installation procedure is:

- 1] Place the IMS CD in your CD-ROM drive.
- 2] The CD Front End should automatically start, if not, click Start>Run on the Start Menu. Browse to your CD-ROM Drive and select "IMS.exe"
- 3] On the screen that will open click the MDrive button.
- 4] Select the appropriate release of the Motor Interface. Follow the onscreen prompts to complete installation.

Start-up

Select "Start>Programs>IMS Motor Interface>IMS Motor Interface". The Configuration Utility will automatically scan your LPT ports for the connected MDrive and configure communications. The connection status and port are displayed at the bottom of the configuration screen (See Figure 1.4.1).

Configuration Parameters Explained

There are 3 configuration parameters for the MDrive. Parameter settings are automatically saved to memory when the "SET" button is clicked on the Configuration Utility screen. These parameters may all be changed on-the-fly.

Table 1.4.1 summarizes the parameters and their function, range, units and default setting.

MDrive Setup Parameters				
PARAM.	FUNCTION	RANGE	UNITS	DEFAULT
MHC	Motor Hold Current	0-100	percent	5
MRC	Motor Run Current	1-100	percent	25
MSEL	Microstep Resolution	2, 4, 5, 8,10, 16, 25, 32, 50, 64, 125, 128, 250, 256	microsteps/step	256

Table 1.4.1: Setup Parameters

Motor Holding Current (MHC)

The MHC parameter sets the motor holding current as a percentage of the full output current of the driver. If the hold current is set to 0, the output circuitry of the driver section will disable when the hold current setting becomes active.

The hold current setting becomes active 200ms following the last step clock pulse.

Motor Run Current (MRC)

The Motor Run Current (MRC) parameter sets the motor run current to a percentage of the full output current of the driver section.

Microstep Resolution Select (MSEL)

The MSEL parameter specifies the microstep resolution of the MDrive. See Table 1.4.2 for valid MSEL parameter settings.

MDrive Microstep Resolution Settings (MSEL)	
MSEL=	Steps/Rev
Binary Microstep Resolution Settings	
2	400
4	800
8	1,600
16	3,200
32	6,400
64	12,800
128	25,600
256	51,200
Decimal Microstep Resolution Settings	
5	1,000
10	2,000
25	5,000
50	10,000
125	25,000
250	50,000

Table 1.4.2: Microstep Resolution Settings

Configuring the MDrive Using SPI

The MDrive may be setup and operated without the included GUI, the IMS Motor Interface.

If the optional cable is not being used you will need to make one using the diagram shown on page 17 of this document.

Timing Notes

- 1) MSb and MSB first
- 2) 8 bit bytes
- 3) 100kHz SCK
- 4) Data In (MOSI) on rising clock
- 5) Data Out (MISO) on falling clock

SPI Commands

SPI Commands and Parameters				
	CMD/PRM	Hex	Range	Notes
SPI Commands	READ ALL	0x40		Reads the hex value of all parameters.
	WRITE ALL	0x80		Writes the hex value to the following parameters: MRC, MHC, MSEL.
Data READ	"M"	0x4D		M character precedes every read.
	Version MSB	0x10	<1-8>.<0--9>	Firmware version.subversion eg. 1.0
	Version LSB	0x00	<0-99>	Firmware revision. Appends to Version MSB eg .00
	MRC	0x19	1-100%	Motor Run Current
	MHC	0x05	0-100%	Motor Hold Current
	MSEL	0x00	0*, 2-250	Microstep Resolution
Data WRITE	MRC		1-100%	Motor Run Current
	MHC		0-100%	Motor Hold Current
	MSEL		0*, 2-250	Microstep Resolution

*0 = 256 Microsteps/Step Resolution

Table 1.4.3: SPI Command Summary

Examples

```

READ All  MOSI: 40 00 FF FF FF FF FF FF
           MISO: XX 4D 10 00 19 05 00
           M, 1.0.00, 25, 5, 256
           Name MSB LSB MRC MHC MSEL
                VERSION
                DUMMY

WRITE All MRC=75, MHC=25, MSEL=250
          MOSI: 80 4B 19 FA FF
          MISO: XX 4D FF FF FF
                DUMMY
    
```

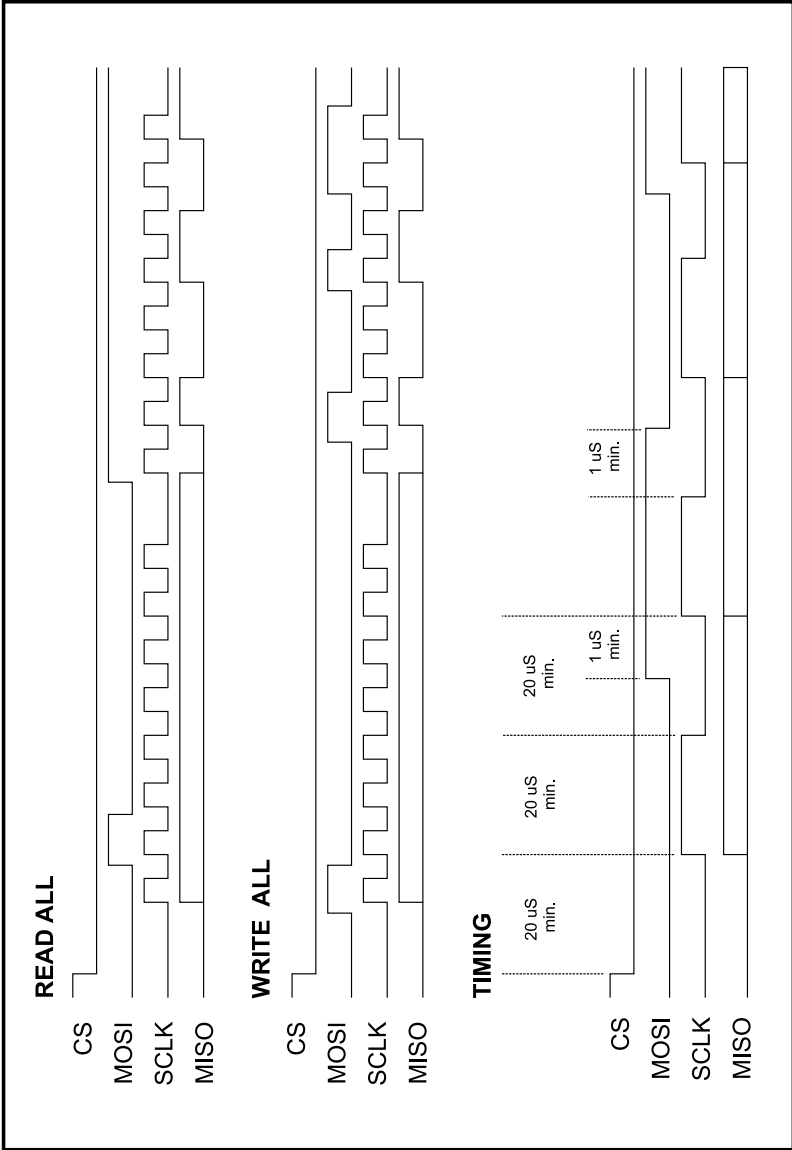

Figure 1.4.2: SPI Waveforms & Timing Diagram

SECTION 1.5

Interfacing The Variable Speed Control MDrive

Section Overview

This section covers the hardware interface of the MDrive versions with integrated variable speed control electronics. Refer to Section 1.6 for Parameter setup and configuration. Covered in the section are:

- Layout and Interface Guidelines
- Interfacing Power and Speed Control Inputs (Connector P1)
- Interfacing the SPI Interface (Connector P2)

Layout and Interface Guidelines

Logic level cables must not run parallel to power cables. Power cables will introduce noise into the logic level cables and make your system unreliable.

Logic level cables must be shielded to reduce the chance of EMI induced noise. The shield needs to be grounded at the signal source to AC ground. The other end of the shield must not be tied to anything, but allowed to float. This allows the shield to act as a drain.

Power supply leads to the driver need to be twisted. If more than one MDrive is to be connected to the same power supply, run separate power and ground leads from the supply to each MDrive.

Recommended Wiring

The following wiring/cabling is recommended for use with the MDrive:

Power

Belden Part# 9740 or equivalent 18 Gauge

Logic Wiring

Wire Size 20-22 AWG

General Practices

The following wire strip length is recommended:

Wire Strip Length 0.250" (6.0 mm)



WARNING! Do not connect or disconnect any wiring when power is applied!



WARNING! See Part II for power supply requirements for the MDrive17, Part III for the MDrive23.

Interfacing Power and Speed Control Inputs (Connector P1)

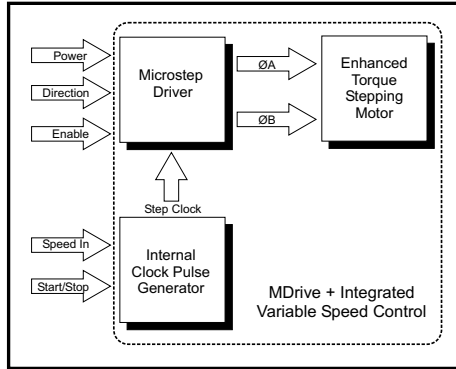

Figure 1.5.1: MDrive Variable Speed Control Block Diagram

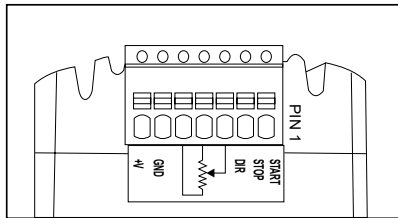

Figure 1.5.2: P1 Pin Configuration for the MDrive Variable Speed Control

MDrive Variable Speed Control Connector P1 Configuration			
PIN #	FLYING LEAD	FUNCTION	DETAILS
1	--	Stop/Start Input	This input will start the internal pulse generator when pulled LOW by means of a switch or sinking input. It is internally pulled up to +5VDC.
2	--	CW/CCW Direction Input	This input is used to change the direction of the motor. In unidirectional mode a logic HIGH (open) = CW.
3	--	Speed Control Input	0 to +5 VDC/PWM/4 - 20mA Speed Control Input
4	--	+5VDC Output	+5VDC Output. This output is not to be used to power external devices.
5	--	Ground	Logic Ground.
6	--	Power Ground	Power Supply Ground (Return).
7	--	+V	+12 to +48 VDC (MD17 & MD23-4) +24 to +75 VDC (MD23-7)

Table 1.5.1: P1 Pin Description for the MDrive Variable Speed Control

Interfacing the MDrive Speed Control Inputs

The MDrive has 2 logic inputs which are located on connector P1. These inputs control the ON/OFF state of the internal clock pulse generator and the direction of motor rotation. Each input is internally pulled-up to +5 Volts and may be connected to sinking outputs on a controller such as the IMS LYNX or a PLC. These inputs are:

- 1] Start/Stop (P1:1)
- 2] Direction (P1:2)

There are also three connections for a Joystick or a Potentiometer. These are:

- 1] Speed Control Input (P1:3)
- 2] +5V Output (P1:3)
- 3] Logic Ground (P1:3)

The Speed Control input may also be interfaced to a PLC 15 - 25 kHz PWM output or a 4 - 20mA output analog device. If a 4 - 20mA device is used the 4 - 20mA input mode **MUST** be selected on the Analog Speed Control Interface software.

Figure 1.5.3 and 1.5.4 illustrates Interface options for the Variable Speed Control Version of the MDrive.

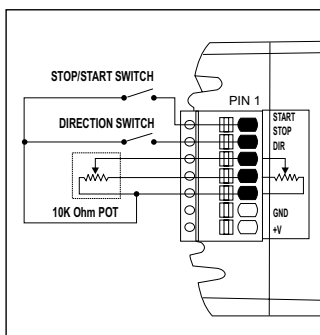

Figure 1.5.3: Interfacing the MDrive Speed Control using Switches and a Potentiometer

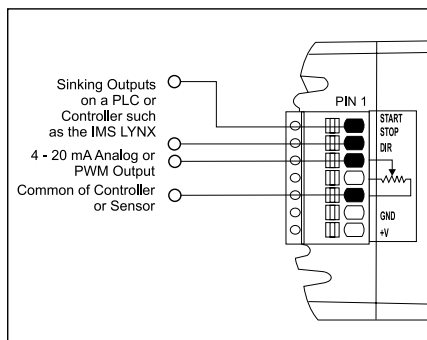

Figure 1.5.4: Interfacing the MDrive Speed Control using a 4 -20 mA Analog or PWM Output

Velocity Control Input Characteristics

Start/Stop (Pin 1)

The /Start input is internally pulled-up to +5VDC through a 4.99k Ω resistor. When in a logic HIGH, or disconnected, state the internal step clock generator will be off. Connecting this input to logic ground (pin 5) or a sinking output in a LOW state will enable the internal step clock oscillator.

This input may be controlled by means of a switch between the input (pin 1) and logic ground (pin 5) or a sinking output. Leakage current due to external interface circuitry must not exceed 200 micro amps.

Direction (Pin 2)

The CW/CCW direction input is internally pulled-up to +5VDC through a 4.99k Ω resistor.

This input may be connected by means of a switch between the input (Pin 2) and logic ground (Pin 5) or a sinking output. Leakage current due to external interface circuitry must not exceed 200 micro amps.

Speed Control Input (Pin 3)

The Speed Control input is the input by which the internal step clock frequency, hence the velocity of the axis, is controlled.

This 0 - 5 volt analog input will typically be interfaced using a 10k Ω potentiometer as illustrated in Figure 1.5.3, a joystick wiper, a 4-20mA analog output or a 15 to 25 kHz (100% Duty Cycle) output of a PLC. If using a 4-20mA output the 4 - 20mA input mode must be selected on the Speed Control Interface software.

If a constant velocity is desired, the speed control input can be connected directly to the +5VDC output and the desired velocity set using the VM parameter. When the START input is brought to a logic LOW state, the motor will begin to move at the velocity specified by the VI variable. It will then accelerate at the rate specified by ACCL until it reaches the speed set by VM.

+5VDC Output (Pin 4)

The +5VDC output is to be connected to the signal end of the 10k Ω potentiometer used to control velocity **only**. It is not the design intent of this output to supply power to external loads.



WARNING: The +5 VDC Output (P1:4) is intended to control velocity **ONLY!** It is not to be used to power external devices!



NOTE: If using the 4 - 20mA input mode this mode **MUST** be selected on the Speed Control Interface software. By default the MDrive Speed Control is configured for 0 - 5VDC or PWM input mode.

Interfacing the MDrive SPI Interface (Connector P2)

The SPI communications connector uses a 10 pin IDC header. The recommended method of connecting to this connector is the Parameter Setup Cable MD-CC100-000. In addition to offering ease of connection, this cable features a built-in logic level shifter for computers that run on 3.3V output ports. This low-cost accessory eliminates the need of wiring the SPI interface.

MDrive Connector P2 (SPI Interface)		
Pin #	Function	Description
1	N/C	No Connect.
2	N/C	No Connect.
3	N/C	No Connect.
4	CS	Chip Select.
5	GND	Communications Ground.
6	+5VDC	+5 VDC Output (SEE WARNING BELOW!).
7	MOSI	Master Out/Slave In.
8	CLK	Clock.
9	N/C	No Connect.
10	MISO	Master In/Slave Out.

Table 1.5.2: P2 Pin Assignment and Description



WARNING! The +5VDC output on connector P2 is used for the setup cable **ONLY!** This output is not designed to power external devices!

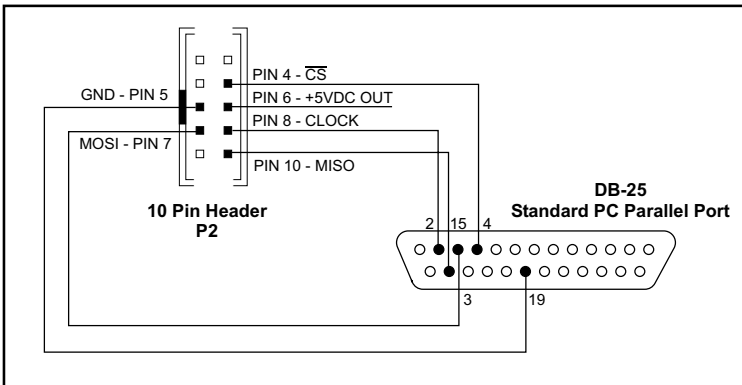

Figure 1.5.5: SPI Interface Wiring and Connections



NOTE: Should you choose to make your own parameter setup cable be advised the 3.3V output parallel ports on some laptop PCs may not be sufficient to communicate with the device.

Minimum Required Connections

The connections shown in Figure 1.5.6 are the minimum required to operate the MDrive Variable Speed Control.

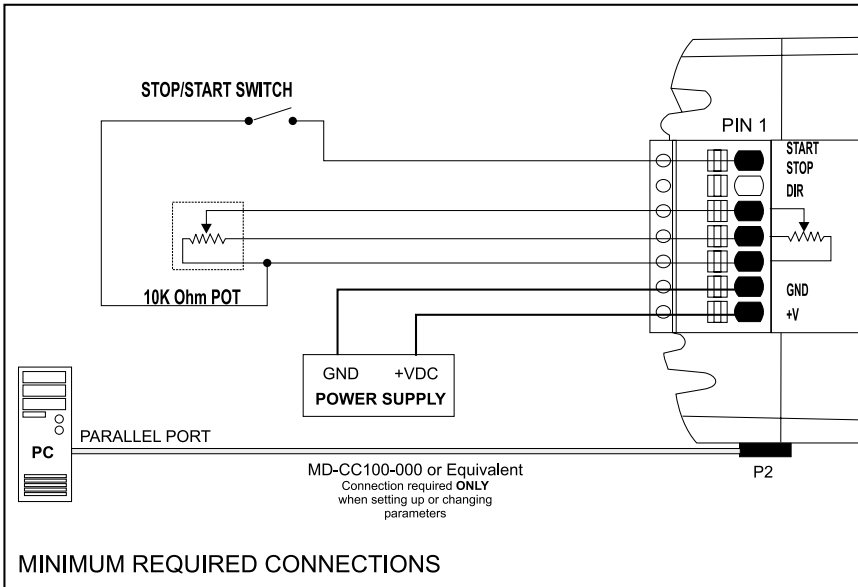

Figure 1.5.6: Minimum Required Connections

SECTION 1.6

Configuring The MDrive Variable Speed Control

The IMS Speed Control configuration utility is easy to install and use software and is required for configuring the MDrive. This powerful tool is available on the IMS CD or for download at www.imshome.com. This utility is the only method for configuring your MDrive speed control. The configuration utility features the following:

- Easy installation.
- Ease of use via single screen interface.
- Automatic communication configuration.
- Will not allow out-of-range values to be set.
- Tool-tips display valid range settings for each option.



Figure 1.6.1: Speed Control Configuration Utility Screen

Installation

To install and use the configuration utility you need a Pentium class or higher PC running Windows 95/98. The Windows NT version of this software is required for Windows NT 4.0 (SP6 or greater) or Windows 2000 (SP1 or greater). The installation procedure is:

- 1] Place the IMS CD in your CD-ROM drive.
- 2] The CD Front End should automatically start, if not, click Start>Run on the Start Menu. Browse to your CD-ROM Drive and select "IMS.exe"
- 3] On the screen that will open click the MDrive button.
- 4] Select the appropriate release of the Speed Control Interface. Follow the onscreen prompts to complete installation.

Start-up

Select "Start>Programs>Analog Speed Control>Analog Speed Control". The configuration utility will automatically scan your LPT ports for the connected MDrive and configure communications. The connection status and port are displayed at the bottom of the configuration screen (Figure 1.6.1).

Configuration Parameters Explained

There are 11 configuration parameters for the MDrive. Parameter settings are automatically saved to memory when the “SET” button is clicked on the configuration utility screen.

Table 1.6.1 summarizes the parameters and their function, range, units and default setting.

Speed Control Parameters				
Parameter	Function	Range	Units	Default
ACCL	Acceleration/Deceleration	2000-65000	Steps/sec ²	2000
C	Joystick Center Position	0 to 1022 (0.005 to 4.995)	Counts (Volts)	0 (0.000)
DB	Potentiometer/Joystick Deadband	0 to 255 (0.000 to 1.245)	Counts (Volts)	1 (0.005)
DCLT	Deceleration Type	Decelerate Do Not Decelerate	-	Decel
FS	Full Scale of the Potentiometer/Joystick	1 to 1023 (0.005 to 4.995)	Counts (Volts)	1023 (4.995)
MHC	Motor Holding Current	0 - 100	Percent	5
MRC	Motor Run Current	1 - 100	Percent	25
MODE	Input Mode	Voltage/PWM 4 - 20mA	-	Voltage/ PWM
RANGE	VI / VM Range Setting	1 - 8	-	3
MSEL	Resolution Select Parameter	See Table	per step divisor	256
VI	Initial Velocity	1-10000	Steps/sec.	800
VM	Maximum Velocity	1-10000	Steps/sec.	20000

Table 1.6.1: MDrive Parameter Summary

Acceleration (ACCL)

The ACCL parameter sets the acceleration and deceleration in steps per second².

Joystick Center Position (C)

The parameter sets the center position of the joystick. It can be set by two methods. Using method one the user will manually enter a value between 0 (default) and 1022 into the parameter box. This count will represent the voltage that the MDrive will interpret as the zero-reference position. Any voltage seen on the speed control input will accelerate from 0 to the maximum set velocity. The second method is to select Analog>Initialize from the menu bar of the configuration utility. Move the joystick or rotate the pot to the end of travel on both directions, move or rotate the input device to the desired center and click the “Accept” button. See the setup procedure located in “Setting the Configuration Parameters”, the next subsection of this document.

Potentiometer Deadband (DB)

The DB parameter sets the deadband of the potentiometer. The range for this parameter is a relative term as the actual deadband value is based upon the settings of the VI and VM parameters. The deadband is the amount of deflection seen on the potentiometer until the velocity is changed. With DB=1

it is possible that the motor will oscillate between two velocities. This can be eliminated by setting the deadband to a higher value.



USAGE NOTE: If the motor oscillates between two velocities, increase the potentiometer deadband to a higher value. This will add coarseness to the pot and eliminate the oscillation.

Note that when the voltage seen at the speed control input is $\leq 0.005V$, the step clock output of the oscillator will be 0. When the potentiometer or joystick deflects to the level specified by the DB parameter the axis will start to accelerate, beginning at the velocity specified by the VI, or initial velocity parameter.

Deceleration Type (DCLT)

This parameter sets the motor deceleration to an ON/OFF state. If Decel is selected on the speed control utility, the motor will decelerate to stop at the rate specified by the ACCL parameter. If No Decel is selected, the motor will hard stop.

Full Scale (FS)

The full scale parameter sets the deflection of the potentiometer or joystick. While the min/max range of the speed control input is 0 to 1023 counts (0.005 to 4.995 volts) (0 counts = no motion, 1023 counts = max velocity, or VM) the user has the option of setting the full scale to a different value. For instance, setting FS=500 counts (2.411 volts) will cause the MDrive’s oscillator to output the appropriate step clock frequency set for VM when the voltage on the speed control input is 2.411V.

Motor Holding Current (MHC)

The MHC parameter sets the motor holding current as a percentage of the full output current of the driver. If the hold current is set to 0, the output circuitry of the driver will disable when the hold current setting becomes active.

The hold current setting becomes active 200ms following the last step clock pulse.

Motor Run Current (MRC)

The Motor Run Current (MRC) parameter sets the motor run current to a percentage of the full output current of the driver.

RANGE PARAMETER SETTINGS								
RANGE	1	2	3	4	5	6	7	8
VI	200	100	50	20	10	5	2	1
VM	100000	50000	25000	10000	5000	2500	1000	500

Table 1.6.2: RANGE Parameter Settings

Input Mode

The Input mode setting selects the input method to be used, either Voltage (0 - 5 VDC and PWM (15 to 25kHz, 100% duty cycle) or 4 - 20mA.

Velocity Range (RANGE)

The RANGE parameter specifies the maximum ranges available for the initial velocity (VI) and the maximum velocity (VM). When the range is set to a value, the VI and VM parameters will automatically default to the value specified by the range setting. The value of VI and VM can then be set within the range specified by RANGE. Table 1.6.2 illustrates the range settings.

Microstep Resolution Select (MSEL)

The MSEL parameter specifies the microstep resolution of the MDrive. See Table 1.6.3 for valid MSEL parameter settings.

MDrive Microstep Resolution Settings (MSEL)	
MSEL=	Steps/Rev
Binary Microstep Resolution Settings	
2	400
4	800
8	1,600
16	3,200
32	6,400
64	12,800
128	25,600
256	51,200
Decimal Microstep Resolution Settings	
5	1,000
10	2,000
25	5,000
50	10,000
125	25,000
250	50,000

Table 1.6.3: MSEL Parameter Settings

Initial Velocity (VI)

The VI parameter establishes the initial velocity of the controlled axis in steps per second. The setting of this parameter represents the slowest speed the motor will turn. This is the velocity of the axis when the voltage on the speed control input = 0V. The valid settings for VI is dependent on the RANGE setting.

Maximum Velocity (VM)

The VM parameter establishes the maximum velocity of the controlled axis in steps per second. The setting of this parameter represents the highest speed that the motor will turn. This is the velocity of the axis when the voltage on the speed control input = 5V. The valid setting for VM is dependent on the RANGE setting.

Setting the Configuration Parameters

In order to follow the procedures set forth in this subsection, the following is necessary:

- The Parameter Setup Cable (MD-CC100-000) or equivalent must be connected between your PC Parallel (Printer) Port and the 10 pin IDC connector (P2) on the MDrive.
- The Analog Speed Control configuration utility must be installed and operating on your PC. Correct connection of the device and operation of the software will be indicated by a "Connected - LPTx" message at the bottom of the configurator screen.
- The Stop/Start input must be in a HIGH (Disconnected, Stopped) state.

Configuring the MDrive for Unidirectional Operation

When operating as a unidirectional device, the internal clock pulse generator will output step clock pulses to the MDrive's driver section. The initial and maximum frequency of these pulses, and the rate which they accelerate between these values, is established by the following four parameters:

- 1] Initial Velocity (VI)
- 2] Maximum Velocity (VM)
- 3] Acceleration (ACCL)
- 4] Velocity Range (RANGE)



Figure 1.6.2: Speed Control Configuration Utility Screen

Set the Run Current (MRC) and the Holding Current (MHC) to the desired value.

When using the MDrive in velocity mode the settings for FS, C and DB will likely be left in their default state. These three parameters may be displayed as either counts or volts. The displayed value is changed by clicking the "Cts" to the right of the parameter's text box. It may be changed from volts back to counts by clicking "volts".

If the motor oscillates between frequencies, increase the potentiometer deadband (DB). If desired, these may be changed. For example: Setting the FS parameter to 511 would configure the MDrive such that it will be at maximum velocity when the potentiometer is at 1/2 of its full deflection.

Test the settings by pulling the Stop/Start input to ground by means of a switch or sinking output. Turn the potentiometer between its stops, the motor should accelerate and decelerate between the VI and VM settings. Note that there will be no motion at the zero reference point of the potentiometer. The motion will not start until the speed control input sees the voltage equivalent of 0 + DB.

Fine-tune the ACCL, VI, VM and RANGE settings to the requirements of your application. Clicking the “Set” button saves the parameter settings to non-volatile memory.

Configuring the MDrive for Bidirectional Operation

When setting the MDrive for bidirectional operation, it is necessary that the joystick or pot be calibrated. First, a center position must be established, as well as the full scale range of the input device in two directions. The following steps outline the calibration procedures.

- 1] With the input device in the center position, click “Analog>Initialize” on the menu bar.
- 2] Move the input device to its full scale position, first in the max direction, then in the min direction. Re-center the input device.
- 3] Click the “Accept” button.
- 4] Set the other parameters to the desired value.
- 5] Click the “Set” button to save the parameter settings to non-volatile memory.



Figure 1.6.3: Initialization Mode

PART II

MDRIVE 17 INTEGRATED MOTOR AND ELECTRONICS

R o t a r y

L i n e a r A c t u a t o r



SECTION 2.1

MDrive17 Power Supply & Thermal Requirements

Power Supply Specifications

Motor Power Supply Specifications	
Specification	
Recommended Supply Type	Unregulated DC
Ripple Voltage	±10%
Output Voltage	+12 to +45 VDC
Output Current	3A Peak

Power supply current requirements = 2A (MAX) per MDrive17. Actual power supply current will depend upon load and duty cycle.

Table 2.1.1: Recommended Power Supply Specifications

Recommended IMS Power Supplies

Listed below are the power supplies recommended for use with the MDrive17.

Unregulated Linear Supply

IP402

Input Specifications

*AC Input Voltage Range 102-132VAC

Output Specifications

Voltage (Nominal - No Load) 40 VDC

Current (Continuous) 2 Amps

***Options**

IP402-240 240VAC Input

Thermal Specifications

Because the MDrive consists of two core components, a drive and a motor, close attention must be paid to the thermal environment where the device is used. The following maximum temperatures apply to the MDrive 17:

Ambient Temperature

Max 85°C

Heatsink Temperature

Max 100°C

Motor Temperature

Max 100°C

Section 2.2

Rotary MDrive17 Specifications

Section Overview

This section contains mechanical, motor and electrical specifications specific to each version of the Rotary MDrive17. Shown are:

- Mechanical Specifications
- Motor Specifications
- Electrical Specifications

Mechanical Specifications

Dimensions in inches (mm)

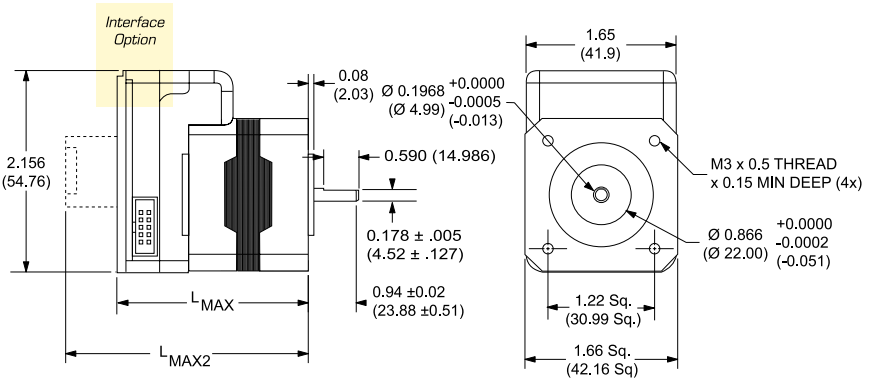

Standard Rotary L_{MAX}	
Stack	in (mm)
1713	2.187 (55.56)
1715	2.407 (61.15)
1719	2.786 (70.77)

Encoder/Control Knob L_{MAX2}	
Stack	in (mm)
1713	2.744 (69.71)
1715	2.965 (75.30)
1719	3.343 (84.92)

Differential Encoder L_{MAX2}	
Stack	in (mm)
1713	2.957 (75.11)
1715	3.177 (80.70)
1719	3.492 (88.69)

Figure 2.2.1: Rotary MDrive17 Mechanical Specifications

Interface Options - All Versions

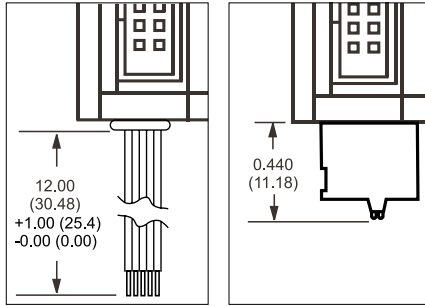

**Flying Leads Pluggable Clamp Type
Terminal Block**

Figure 2.2.2: Interface Options

Motor Specifications



NOTE! The following specifications apply to all rotary variants of the MDrive17, the standard rotary as well as the encoder and control knob versions.

MDrive1713 Motor Specifications and Speed/ Torque Curves

MD1713	
Holding Torque oz-in (N-cm)	32 (22.6)
Detent Torque oz-in (N-cm)	2.0 (1.4)
Rotor Inertia oz-in-sec ² (kg-cm ²)	0.00053 (0.038)
Weight (Motor+Driver) oz (gm)	8.26 (234.2)

Table 2.2.1: MD1713 Motor Specifications

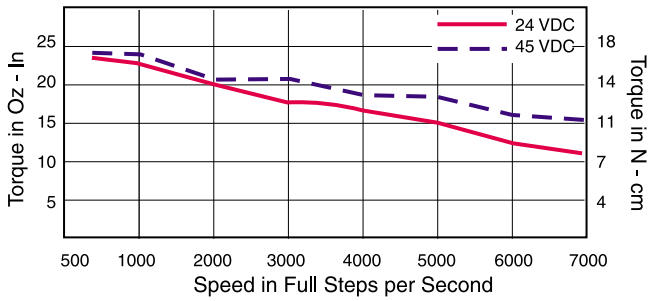

Figure 2.2.3: Rotary MDrive 1713 Speed/Torque Data (100% Current)

MDrive1715 Motor Specifications and Speed/Torque Curves

MD1715	
Holding Torque oz-in (N-cm)	60 (42.4)
Detent Torque oz-in (N-cm)	2.50 (1.81)
Rotor Inertia oz-in-sec ² (kg-cm ²)	0.00080 (0.057)
Weight (Motor+Driver) oz (gm)	10.42 (295.1)

Table 2.2.2: Rotary MDrive 1715 Motor Specifications

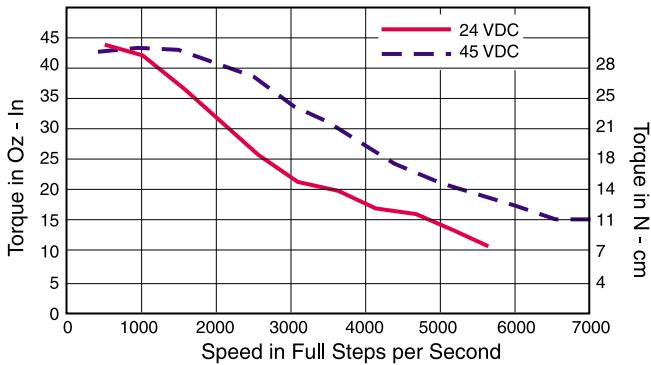

Figure 2.2.4: Rotary MDrive 1715 Speed/Torque Data (100% Current)

MDrive1719 Motor Specifications and Speed/Torque Curves

MD1719	
Holding Torque oz-in (N-cm)	74.9 (52.9)
Detent Torque oz-in (N-cm)	4.0 (2.8)
Rotor Inertia oz-in-sec ² (kg-cm ²)	0.00116 (0.082)
Weight (Motor+Driver) oz (gm)	11.80 (334.5)

Table 2.2.3: Rotary MDrive 1719 Motor Specifications

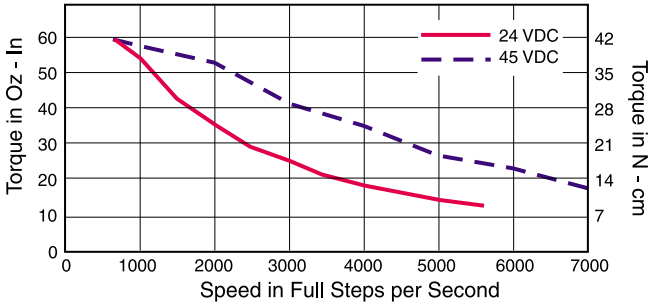

Figure 2.2.5: Rotary MDrive 1719 Speed/Torque Data (100% Current)

Electrical Specifications

MDrive17 Electrical Characteristics					
Specification	Test Condition	Min	Typ	Max	Unit
Input Voltage		12		48	V
Input Forward Current	Step Clock and Direction		7.0	15	mA
Input Forward Voltage	Step Clock and Direction		1.4	1.7	V
Input Forward Current	Enable		5.0	9.4	mA
Input Forward Voltage	Enable		1.1	1.4	V
Input Reverse Breakdown Voltage	Isolated Inputs	5			V

Table 2.2.4: Electrical Specifications

Force/Speed Curve: 24 VDC

Refer to Table 2.3.2 for screw pitch information

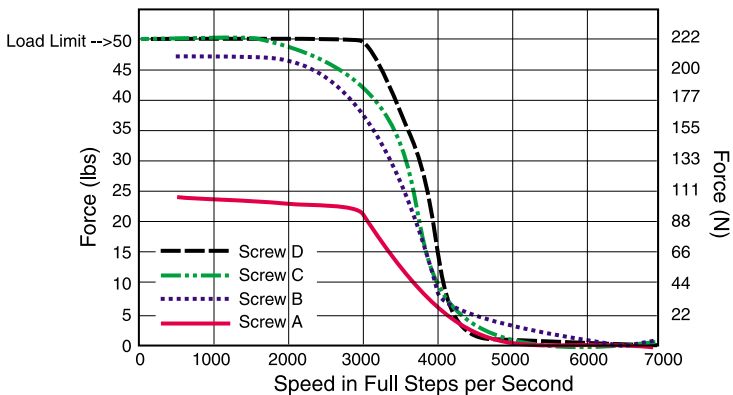

Figure 2.3.2: Force/Speed Curve - 24VDC (100% Current)

Force/Speed Curve: 45 VDC

Refer to Table 2.3.2 for screw pitch information

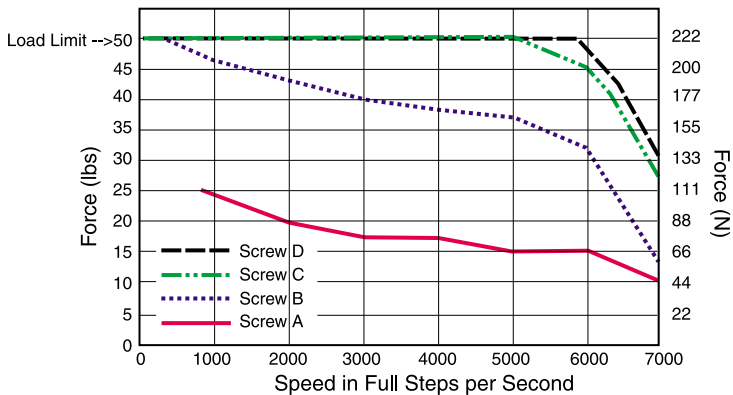

Figure 2.3.3: Force/Speed Curve - 45VDC (100% Current)

MDrive 23 ACME Screws	
Screw	Travel/Full Step - Inches (mm)
A	0.001 (0.0254)
B	0.000833 (0.0211582)
C	0.0005 (0.0127)
D	0.0004167 (0.01058418)
E	0.0003125 (0.0079375)

Table 2.3.2: ACME Screws for the MDrive17 Linear Actuator

PART III

MDRIVE 23 INTEGRATED MOTOR AND ELECTRONICS

R o t a r y

L i n e a r A c t u a t o r



SECTION 3.1

MDrive23 Power & Thermal Requirements

Motor Power Supply Requirements		
Specification	48V MD23 (-4)	75V MD23 (-7)
Recommended Supply Type	Unregulated DC	
Ripple Voltage	±10%	
Output Voltage	+12 to +45 VDC	+24 to +75 VDC
Output Current*	3A Peak	4A Peak

The graph above illustrates the power supply current (MAX) per MDrive23. Actual power supply current will depend upon load and duty cycle.

Table 3.1.1: Recommended Power Supply Specifications

Recommended IMS Power Supplies

Listed below are the power supplies recommended for use with both voltage ranges of the MDrive23.

Unregulated Linear Supply

IP404(MD23-4)/IP804(MD23-7)

Input Specifications

*AC Input Voltage Range 102-132VAC

Output Specifications

Voltage (Nominal - No Load) 40 VDC/75 VDC

Current (Continuous) 4 Amps

*Options

IP402-240 240VAC Input

Thermal Specifications

Because the MDrive consists of two core components, a drive and a motor, close attention must be paid to the thermal environment where the device is used. The following maximum temperatures apply to the MDrive23:

Ambient Temperature

Max 85°C

Heatsink Temperature

Max 100°C

Motor Temperature

Max 100°C

SECTION 3.2

Rotary MDrive23 Specifications

Section Overview

This section contains mechanical, motor and electrical specifications specific to each version of the Rotary MDrive23. Shown are:

- Mechanical Specifications
- Motor Specifications
- Electrical Specifications

Mechanical Specifications

Dimensions in inches (mm)

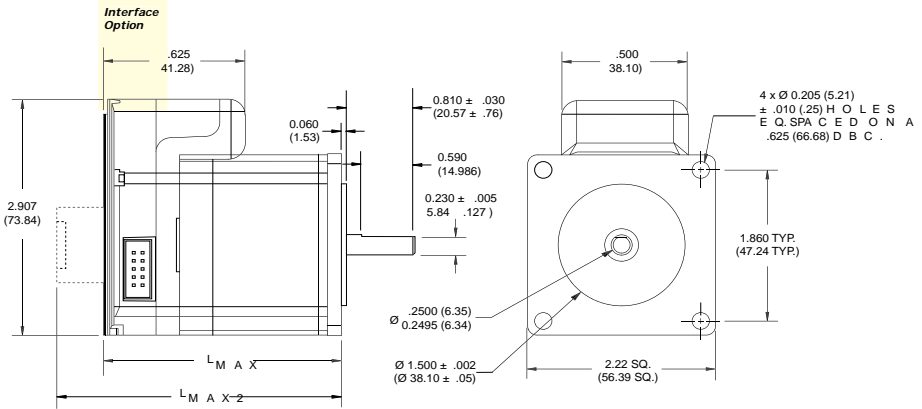

Standard Rotary L _{MAX}	
Stack	in (mm)
2218	2.632(66.85)
2222	3.000 (76.20)
2231	3.960 (100.58)

Encoder/Control Knob L _{MAX2}	
Stack	in (mm)
2218	3.088 (78.44)
2222	3.537 (89.84)
2231	4.416 (112.17)

Differential Encoder L _{MAX2}	
2218	3.282 (83.36)
2222	3.741 (95.02)
2231	4.416 (112.17)

Figure 3.2.1: Rotary MDrive23 Mechanical Specifications

Interface Options - All Versions

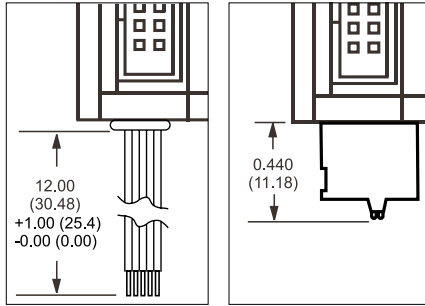

**Flying Leads Pluggable Clamp Type
Terminal Block**

Figure 3.2.2: Interface Options

Motor Specifications



NOTE! The following specifications apply to all rotary variants of the MDrive23, the standard rotary as well as the encoder and control knob versions.

MDrive 2218 Motor Specifications and Speed/Torque Curves

MD2218	
Holding Torque oz-in (N-cm)	90 (64)
Detent Torque oz-in (N-cm)	3.5 (2.5)
Rotor Inertia oz-in-sec ² (kg-cm ²)	0.0025 (0.18)
Weight (Motor+Driver) oz (gm)	20.1 (569.8)

Table 3.2.1: MD2218 Motor Specifications

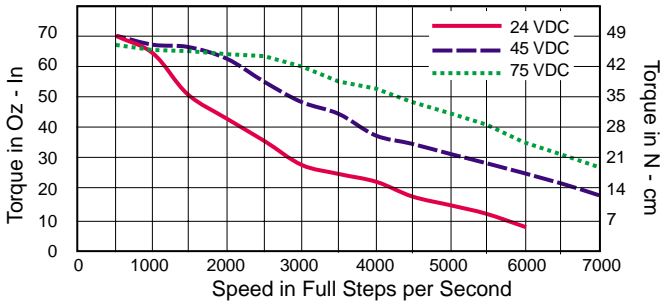

Figure 3.2.3: Rotary MDrive 2218 Speed/Torque Data (100% Current)

MDrive 2222 Motor Specifications and Speed/Torque Curves

MD2222	
Holding Torque oz-in (N-cm)	144 (102)
Detent Torque oz-in (N-cm)	5.6 (3.92)
Rotor Inertia oz-in-sec ² (kg-cm ²)	0.0037 (0.26)
Weight (Motor+Driver) oz (gm)	24.4 (691.7)

Table 3.2.2: Rotary MDrive 2222 Motor Specifications

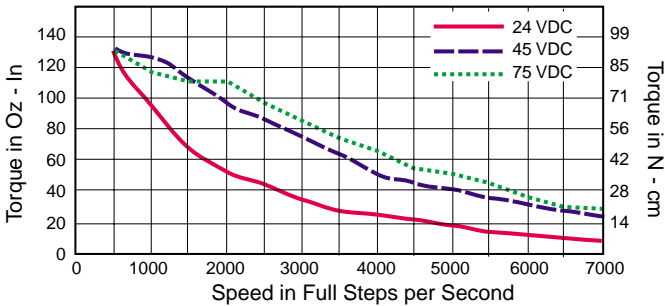

Figure 3.2.4: Rotary MDrive 2222 Speed/Torque Data (100% Current)

MDrive 2231 Motor Specifications and Speed/Torque Curves

MD2231	
Holding Torque oz-in (N-cm)	239 (169)
Detent Torque oz-in (N-cm)	9.7 (6.86)
Rotor Inertia oz-in-sec ² (kg-cm ²)	0.0065 (0.46)
Weight (Motor+Driver) oz (gm)	38.5 (1091.5)

Table 3.2.3: Rotary MDrive 2231 Motor Specifications

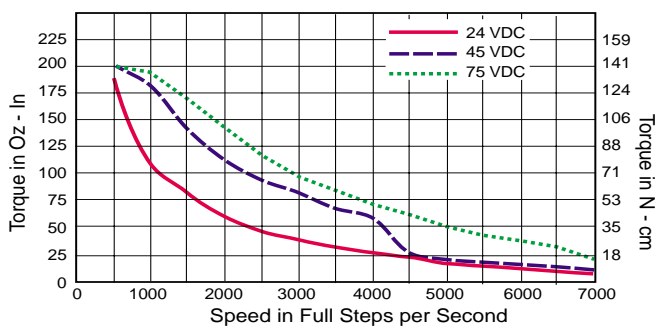

Figure 3.2.5: Rotary MDrive 2231 Speed/Torque Data (100% Current)

Electrical Specifications

MDrive23 Electrical Characteristics					
Specification	Test Condition	Min	Typ	Max	Unit
Input Voltage (-4)		12		48	V
Input Voltage (-7)		24		75	V
Input Forward Current	Step Clock and Direction		7.0	15	mA
Input Forward Voltage	Step Clock and Direction		1.4	1.7	V
Input Forward Current	Enable		5.0	9.4	mA
Input Forward Voltage	Enable		1.1	1.4	V
Input Reverse Breakdown Voltage	Isolated Inputs	5			V

Table 3.2.4: Electrical Specifications

SECTION 3.3

Linear MDrive23 Specifications

Section Overview

This section contains mechanical, motor and electrical specifications specific to each version of the Linear MDrive23. Shown are:

- Mechanical Specifications
- Motor Specifications
- Electrical Specifications

Mechanical Specifications

Dimensions in inches (mm)

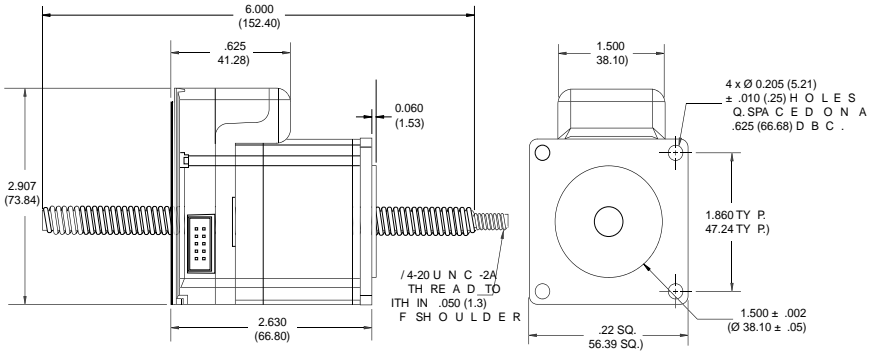

Figure 3.3.1: Linear Actuator MDrive23 Mechanical Specifications

Motor Specifications (Linear)

MDrive23 Linear Actuator	
Weight (Motor+Driver without screw) oz (gm)	20.4 (578.3)
Maximum Thrust lbs (kg)	200 (90.7)

Table 3.3.1: Linear Actuator MDrive23 Motor Specifications

Force/Speed Curve: 24 VDC

Refer to Table 3.3.2 for screw pitch information

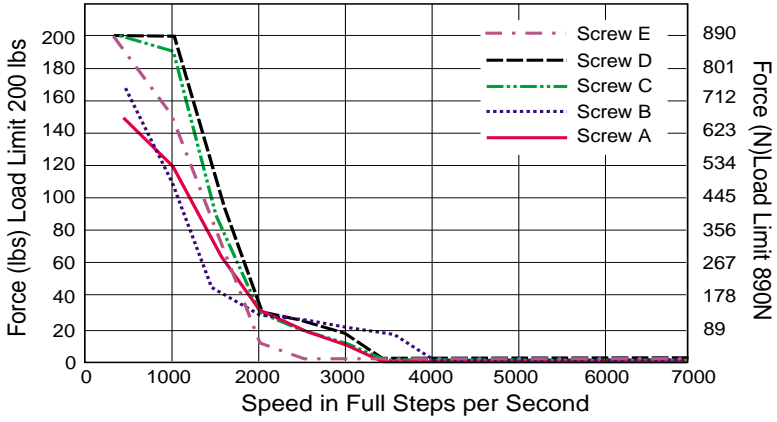

Figure 3.3.2: Force/Speed Curve - 24VDC (100% Current)

Force/Speed Curve: 45 VDC

Refer to Table 3.3.2 for screw pitch information

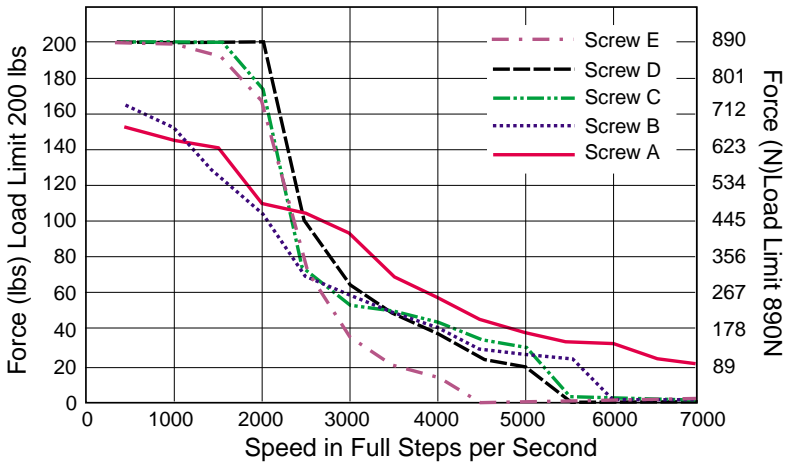

Figure 3.3.3: Force/Speed Curve - 45VDC (100% Current)

Force/Speed Curve: 75 VDC

Refer to Table 3.3.2 for screw pitch information

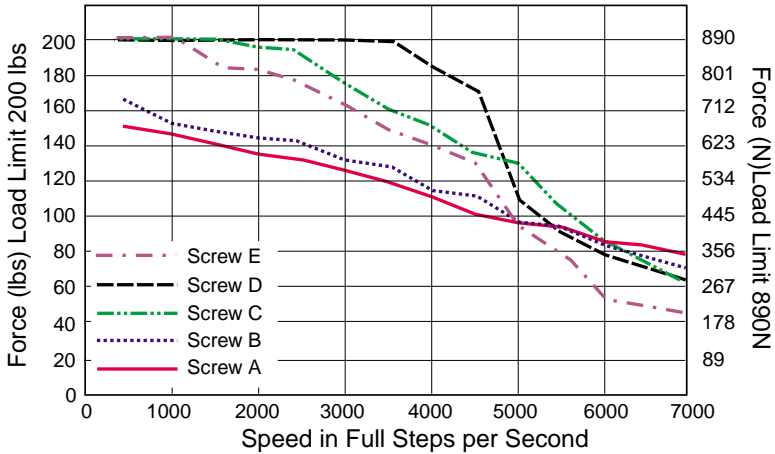

Figure 3.3.4: Force/Speed Curve - 75VDC (100% Current)

MDrive 23 ACME Screws	
Screw	Travel/Full Step - Inches (mm)
A	0.001 (0.0254)
B	0.000833 (0.0211582)
C	0.0005 (0.0127)
D	0.0004167 (0.01058418)
E	0.0003125 (0.0079375)
F	0.002 (0.0508)

Table 3.3.2: ACME Screws for the MDrive 23 Linear Actuator



WARNING: The maximum axial load limit for the MDrive23 motor is 200 lbs (90.7 kg). Do not exceed this rating!



WARNING: The ACME Screw **MUST NOT** deflect more than ± 1 degree perpendicular to the motor face. Additional support for radial loads may be required!

TWENTY-FOUR MONTH LIMITED WARRANTY

Intelligent Motion Systems, Inc., warrants its products against defects in materials and workmanship for a period of 24 months from receipt by the end-user. During the warranty period, IMS will either, at its option, repair or replace products which prove to be defective.

EXCLUSIONS

The above warranty shall not apply to defects resulting from: improper or inadequate handling by customer; improper or inadequate customer wiring; unauthorized modification or misuse; or operation outside of the electrical and/or environmental specifications for the product.

OBTAINING WARRANTY SERVICE

To obtain warranty service, a returned material authorization number (RMA) must be obtained from customer service at (860) 295-6102 before returning product for service. Customer shall prepay shipping charges for products returned to IMS for warranty service and IMS shall pay for return of products to customer. However, customer shall pay all shipping charges, duties and taxes for products returned to IMS from another country.

WARRANTY LIMITATIONS

IMS makes no other warranty, either expressed or implied, with respect to the product. IMS specifically disclaims the implied warranties of merchantability and fitness for a particular purpose. Some jurisdictions do not allow limitations on how long an implied warranty lasts, so the above limitation or exclusion may not apply to you. However, any implied warranty of merchantability or fitness is limited to the 24-month duration of this written warranty.

EXCLUSIVE REMEDIES

If your product should fail during the warranty period, call customer service at (860) 295-6102 to obtain a returned material authorization number (RMA) before returning product for service. Please include a written description of the problem along with contact name and address. Send failed product to: Intelligent Motion Systems, Inc., 370 N. Main St, Marlborough, Connecticut 06447. Also enclose information regarding the circumstances prior to product failure.



INTELLIGENT MOTION SYSTEMS, INC.

Excellence in Motion™

**P. O. Box 457, 370 North Main Street
Marlborough, CT 06447 U.S.A.**

Phone: 860/295-6102

Fax: 860/295-6107

E-mail: info@imshome.com

Home Page: www.imshome.com

WESTERN REGION

IMS Motors Division -

Western U.S. Technical Support -

105 Copperwood Way, Suite H

Oceanside, CA 92054

Phone: 760/966-3162

Fax: 760/966-3165

E-mail Motors Division:

motors@imshome.com

E-mail Western Technical Support:

wtech@imshome.com

Western U.S. Sales Management -

Phone: 949/707-0156

Fax: 949/707-0157

E-mail: wsales@imshome.com

IMS EUROPE

Administration -

Hahnstrasse 10, VS-Schwenningen

Germany D-78054

Phone: +49/7720/94138-0

Fax: +49/7720/94138-2

European Sales Management -

4 Quai Des Etroits

69005 Lyon, France

Phone: +33/4 7256 5113

Fax: +33/4 7838 1537

E-mail: bmartinez@imshome.com

Sales/Tech Support for Germany -

Phone: +49/35205/4587-8

Fax: +49/35205/4587-9

E-mail: hruhland@imshome.com



MDrive Operating Instructions

OM-MD

V02.07.2002