



intelligent motion systems, inc.
Excellence in Motion™



OPERATING INSTRUCTIONS

The information in this book has been carefully checked and is believed to be accurate; however, no responsibility is assumed for inaccuracies.

*Intelligent Motion Systems, Inc., reserves the right to make changes without further notice to any products herein to improve reliability, function or design. Intelligent Motion Systems, Inc., does not assume any liability arising out of the application or use of any product or circuit described herein; neither does it convey any license under its patent rights of others. Intelligent Motion Systems and **IMS**[™] are trademarks of Intelligent Motion Systems, Inc.*

Intelligent Motion Systems, Inc.'s general policy does not recommend the use of its products in life support or aircraft applications wherein a failure or malfunction of the product may directly threaten life or injury. Per Intelligent Motion Systems, Inc.'s terms and conditions of sales, the user of Intelligent Motion Systems, Inc., products in life support or aircraft applications assumes all risks of such use and indemnifies Intelligent Motion Systems, Inc., against all damages.

Table of Contents

Part 1: General Information And Hardware Information

Section 1.1: Introduction to the MDrive17 Motion Control	5
Introduction to the MDrive17 Motion Control	5
Feature Summary	5
Section 1.2: MDrive17 Motion Control Specifications	6
Section Overview	6
Rotary Motor Specifications	6
Mechanical Specifications - Dimensions in Inches (mm)	6
MDrive Motion Control 1713 Motor Specs and Speed/Torque Curves	6
MDrive Motion Control 1715 Motor Specs and Speed/Torque Curves	7
MDrive Motion Control 1719 Motor Specs and Speed/Torque Curves	7
Linear Motor Specifications	7
Mechanical Specifications - Dimensions in Inches (mm)	7
Speed-Force Curve: 24 VDC	8
Linear Actuator MDrive Motion Control 1713 Specs and Speed-Force Curves	8
Speed-Force Curve: 45 VDC	8
MDrive17 Motion Control ACME Screw	9
General Specifications	9
General Specifications	10
Power Supply Requirements	10
Recommended IMS Power Supplies	10
Thermal Specifications	10
Section 1.3: Introduction to the MDrive23 Motion Control	11
Introduction to the MDrive23 Motion Control	11
Feature Summary	11
Section 1.4: MDrive23 Motion Control Specifications	12
Section Overview	12
Rotary Motor Specifications	12
Mechanical Specifications - Dimensions in Inches (mm)	12
MDrive Motion Control 2218 Motor Specs and Speed/Torque Curves	12
MDrive Motion Control 2222 Motor Specs and Speed/Torque Curves	13
MDrive Motion Control 2231 Motor Specs and Speed/Torque Curves	13
Linear Motor Specifications	13
Mechanical Specifications - Dimensions in Inches (mm)	13
Speed-Force Curve: 24 VDC	14
Linear Actuator MDrive Motion Control 2218 Specs and Speed-Force Curves	14
Speed-Force Curve: 45 VDC	14
MDrive23 Motion Control ACME Screw	15
General Specifications	15
General Specifications	16
Power Supply Requirements	16
Recommended IMS Power Supplies	16
Thermal Specifications	16

Part 2: Connecting, Configuring And Programming The MDrive Motion Control

Section 2.1: Interfacing the MDrive Motion Control	19
Section Overview	19
Layout and Interface Guidelines	19
Recommended Wiring	19
Pin Configuration and Descriptions	19
Interfacing Power	20
Interfacing RS-485 Communications	20
Single MDrive	20
Multiple MDrive Motion Control System (Party Mode)	21
Interfacing the Digital I/O	22
Uses of the Digital I/O	22
Interfacing Inputs	22
Interfacing Outputs	24
Interfacing the Analog Input	25
Sample Usage	25
Section 2.2: MDrive Motion Control Software Introduction	26
Section Overview	26
Installing and Using IMS Terminal	26
System Requirements	26
Installation	26
Using the IMS Terminal Software	27
Setting the Programmable Function Keys	28
Upgrading the MDrive Motion Control Firmware	28
MDrive Motion Control Programming	29
Operational Modes	29
Basic Components of MDrive Motion Control Software	29
Instructions	29
Variables	29
Flags	30
Keywords	30
Most Commonly Used Variables and Commands	30

Variables	30
Math Functions	31
Motion Commands	31
I/O Commands	32
System Instructions	32
Program Instructions	32
Section 2.3: MDrive Motion Control Command Set Summary	35
Setup Instructions, Variables and Flags	35
Miscellaneous Instructions, Variables and Flags	35
Motion Instructions, Variables and Flags	35
I/O Instructions, Variables and Flags	36
Program Instructions, Variables and Flags	36
Position Related Instructions, Variables and Flags	37
Encoder Related Instructions, Variables and Flags	37
Mathematical Functions	37
Section 2.4: MDrive Motion Control Command Set	38
Appendix A: ASCII TABLE	64
Appendix B: Error Codes	65

List of Figures

Figure 1.1 Rotary MDrive17 Motion Control Mechanical Specifications	6
Figure 1.2 Rotary MDrive17 Motion Control 1713 Speed/Torque Data	6
Figure 1.3 Rotary MDrive17 Motion Control 1715 Speed/Torque Data	7
Figure 1.4 Rotary MDrive17 Motion Control 1719 Speed/Torque Data	7
Figure 1.5 Linear Actuator MDrive17 Motion Control Mechanical Specifications	7
Figure 1.6 Speed-Force Curve - 24VDC (100% Current)	8
Figure 1.7 Speed-Force Curve - 45VDC (100% Current)	8
Figure 1.8 Rotary MDrive23 Motion Control Mechanical Specifications	12
Figure 1.9 Rotary MDrive23 Motion Control 2218 Speed/Torque Data	12
Figure 1.10 Rotary MDrive23 Motion Control 2222 Speed/Torque Data	13
Figure 1.11 Rotary MDrive23 Motion Control 2231 Speed/Torque Data	13
Figure 1.12 Linear Actuator MDrive23 Motion Control Mechanical Specifications	13
Figure 1.13 Speed-Force Curve - 24VDC (100% Current)	14
Figure 1.14 Speed-Force Curve - 45VDC (100% Current)	14
Figure 2.1 Power Supply Interface	20
Figure 2.2 RS-485 Interface, Single MDrive Motion Control	20
Figure 2.3 RS-485 Interface, Multiple MDrive Motion Control System	21
Figure 2.4 Input Interfaced to a Switch	22
Figure 2.5 Input Interfaced to a PLC	22
Figure 2.6 TTL Interface to an Input Group	23
Figure 2.7 Output Interfaced to an LED	24
Figure 2.8 Output Interfaced to a Relay	24
Figure 2.9 Outputs Interfaced to LED's as a Group	24
Figure 2.10 Analog Input Interface	25
Figure 2.11 IMS Terminal Window	26
Figure 2.12 IMS Terminal Preferences	27
Figure 2.13 IMS Terminal Upgrader Window	28

List of Tables

Table 1.1 Rotary MDI1713 Motor Specifications	6
Table 1.2 Rotary MDI1715 Motor Specifications	7
Table 1.3 Rotary MDI1719 Motor Specifications	7
Table 1.4 Linear Actuator MDrive17 Motion Control Motor Specifications	8
Table 1.5 ACME Screws for Linear Actuator MDrive17 Motion Control	9
Table 1.6 Rotary MDI2218 Motor Specifications	12
Table 1.7 Rotary MDI2222 Motor Specifications	13
Table 1.8 Rotary MDI2231 Motor Specifications	13
Table 1.9 Linear Actuator MDrive23 Motion Control Motor Specifications	14
Table 1.10 ACME Screws for Linear Actuator MDrive23 Motion Control	15
Table 2.1 P1 Pin Configuration and Description	19
Table 2.2 P2 Pin Configuration and Description	20
Table 2.3 Input Functions	22
Table 2.4 I/O Group Truth Table	23
Table 2.5 Output Functions	24
Table 2.6 Microstep Resolution Settings	51

Part 1: General Information and Hardware Specifications

Intentionally Left Blank

Section 1.1

Introduction to the MDrive17 Motion Control

Introduction to the MDrive17 Motion Control

The MDrive17 Motion Control offers the system designer a low-cost, intelligent motion controller integrated with a NEMA 17 high torque stepping motor and a +12 to +48 VDC microstepping drive.

The MDrive17 Motion Control adds a versatile array of functions by combining a complete programmable motion controller with our already compact and cost effective standard MDrive17, adding little cost and no increase in size. Standard offerings include four 5 to 24 volt programmable I/O points, one 10-bit 0 to 5 volt analog input, 0 to 5 MHz step clock rate, microstep resolution up to 51,200 steps per revolution and a full featured easy-to-program instruction set.

The MDrive17 Motion Control communicates using the RS-485 communications protocol, this allows for point-to-point or multi-drop communications using one communications port. Addressing and hardware support up to 62 MDrive nodes in a system. The communications BAUD rate is software selectable and ranges from 4.8 kbps to 115 kbps.

The MDrive17 is also available with an optional closed loop control. The closed loop configuration adds a 512 line (2048 count) internal magnetic rotary encoder with index mark without increasing the length of the unit. Closed loop configuration adds position maintenance, stall detection and find index mark.

Available motor configurations include: single shaft, double shaft with control knob, and long life ACME screw linear actuator. Rotary versions are available in three stack lengths: 13, 15 & 19. Interface connections are accomplished using either a 7 position terminal block or optional 12" flying leads.

Feature Summary

- Integrated Microstepping Drive/Motion Controller with Optional Encoder/NEMA 17 High Torque Stepping Motor
- +12 to +48VDC Input Voltage
- Low Cost
- Extremely Compact
- Available Configurations: Single Shaft*, Linear Actuator, Integral Encoder*, Double Shaft with Knob for Manual Positioning*
- Three Motor Stack Lengths Available*
- Single Power Supply
- Microstep Resolution up to 51,200 Steps Per Revolution
- Open Loop or Optional Closed Loop Control
- Programmable Motor Run and Hold Current Settings
- Four 5 to 24 VDC Programmable I/O Points
- One Analog 10 Bit, 0 to 5 Volt Analog Input
- 0 to 5 MHz Step Clock Rate, Selectable in 0.59 Hz Increments
- RS-485 Communications Protocol
- Communications BAUD Rate Selectable from 4.8 kbps to 115 kbps
- 62 Software Addresses for Multidrop Communications
- Simple 1 and 2 Character Programming Instructions
- Pluggable Terminal Strip or 12" Flying Lead Interface
- Optional Integrated RS-232 to RS-485 Converter/Communications Cable

*Rotary Motor Only

Section 1.2

MDrive17 Motion Control Specifications

Section Overview

This section contains mechanical, motor and electrical specifications specific to each version of the MDrive17 Motion Control. Shown are:

- Rotary Motor Specifications
- Linear Motor Specifications
- General Specifications
- Power Supply Requirements
- Thermal Specifications

Rotary Motor Specifications

Mechanical Specifications - Dimensions in Inches (mm)

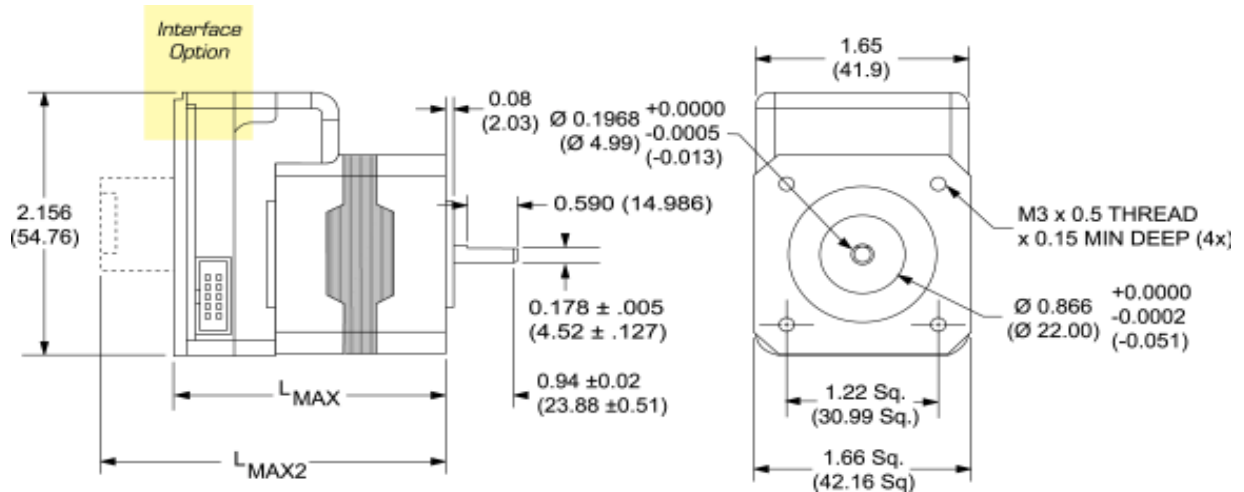

Standard Rotary Motor (L_{MAX})	
Stack	In (mm)
1713	2.187 (55.56)
1715	2.407 (61.15)
1719	2.786 (70.77)

Control Knob (L_{MAX2})	
Stack	In (mm)
1713	2.774 (69.71)
1715	2.965 (75.30)
1719	3.343 (84.92)

Figure 1.1: Rotary MDrive17 Motion Control Mechanical Specifications

MDrive Motion Control 1713 Motor Specs and Speed/Torque Curves

MDI1713	
Holding Torque oz-in (N-cm)	32 (22.6)
Detent Torque oz-in (N-cm)	2.0 (1.4)
Rotor Inertia oz-in-sec ² (kg-cm ²)	0.00053 (0.038)
Weight (Motor+Driver) oz (gm)	8.26 (234.2)

Table 1.1: Rotary MDI1713 Motor Specifications

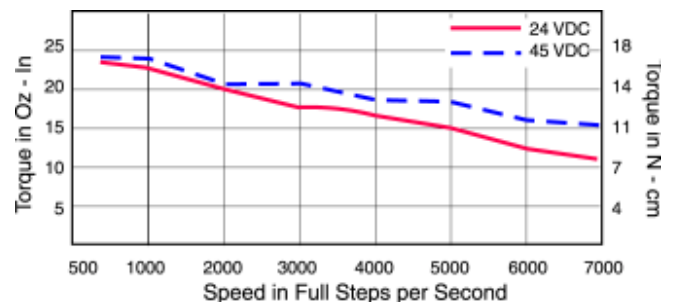

Figure 1.2: Rotary MDrive Motion Control 1713 Speed/Torque Data

MDrive Motion Control 1715 Motor Specs and Speed/Torque Curves

MDI1715	
Holding Torque oz-in (N-cm)	60 (42.4)
Detent Torque oz-in (N-cm)	2.5 (1.8)
Rotor Inertia oz-in-sec ² (kg-cm ²)	0.00080 (0.057)
Weight (Motor+Driver) oz (gm)	10.42 (295.4)

Table 1.2: Rotary MDI1715 Motor Specifications

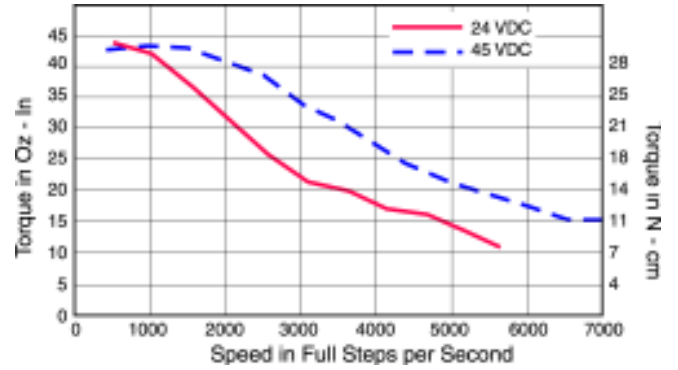

Figure 1.3: Rotary MDrive Motion Control 1715 Speed/Torque Data

MDrive Motion Control 1719 Motor Specs and Speed/Torque Curves

MDI1719	
Holding Torque oz-in (N-cm)	74.9 (52.9)
Detent Torque oz-in (N-cm)	4.0 (2.8)
Rotor Inertia oz-in-sec ² (kg-cm ²)	0.0116 (0.082)
Weight (Motor+Driver) oz (gm)	11.80 (334.5)

Table 1.3: Rotary MDI1719 Motor Specifications

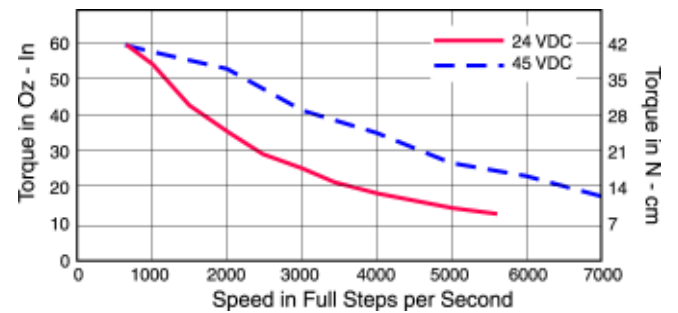

Figure 1.4: Rotary MDrive Motion Control 1719 Speed/Torque Data

Linear Motor Specifications

Mechanical Specifications - Dimensions in Inches (mm)

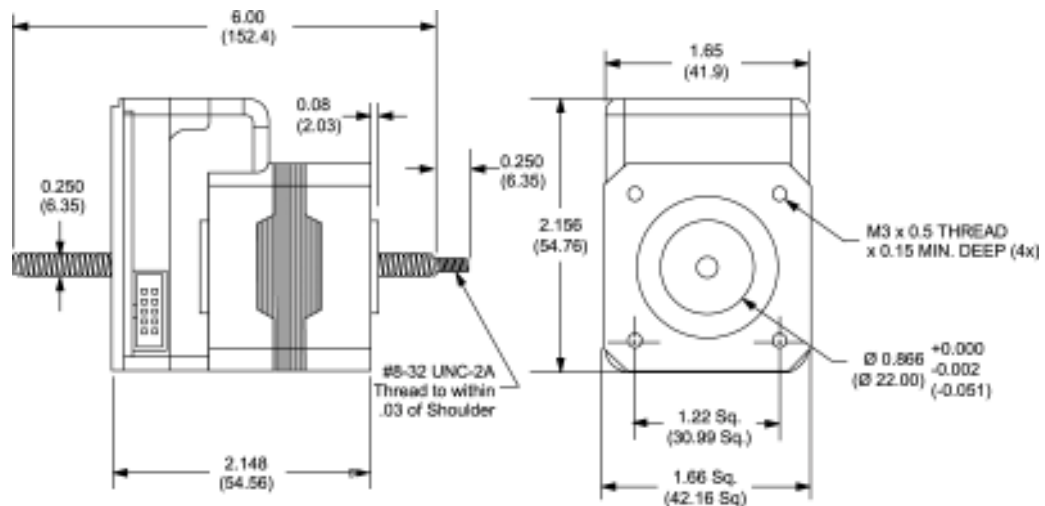

Figure 1.5: Linear Actuator MDrive17 Motion Control Mechanical Specifications

Linear Actuator MDrive Motion Control 1713 Specs and Speed-Force Curves

MDI17 Linear Actuator	
Maximum Thrust lbs (kg)	50 (22.7)
Maximum Screw Deflection	±1°
Backlash inches (mm)	0.005 (0.127)
Weight (Motor+Driver) oz (gm)	9.2 (0.127)

Table 1.4: Linear Actuator MDrive17 Motion Control Motor Specifications

Speed-Force Curve: 24 VDC

Refer to Table 1.5 for screw pitch information

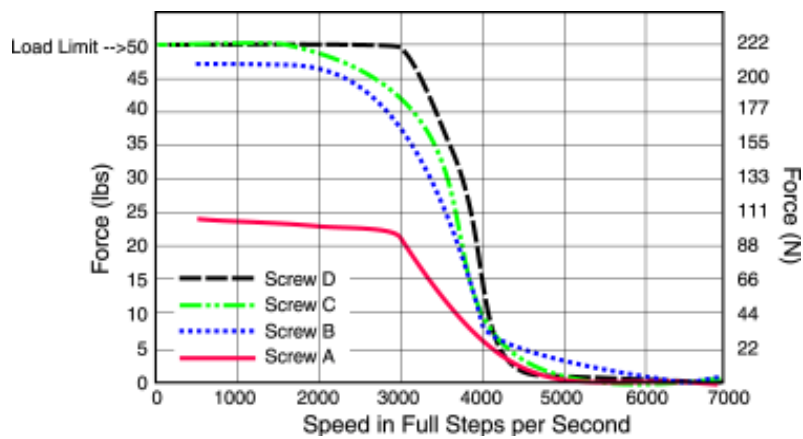

Figure 1.6: Speed-Force Curve - 24VDC (100% Current)

Speed-Force Curve: 45 VDC

Refer to Table 1.5 for screw pitch information

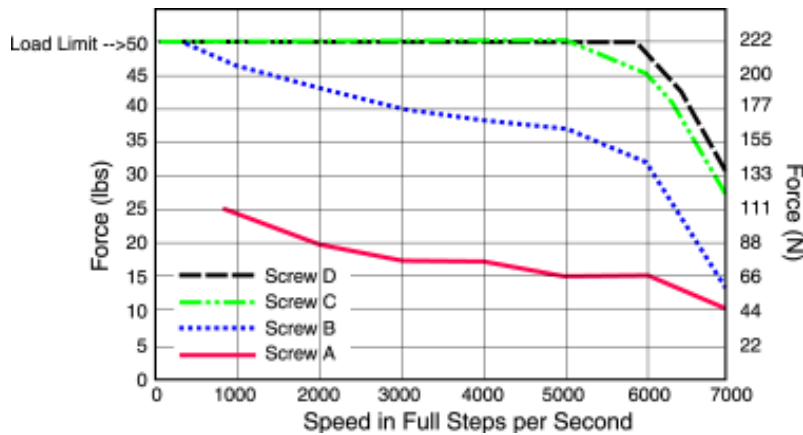



Figure 1.7: Speed-Force Curve - 45VDC (100% Current)

 **WARNING:** The maximum axial load limit for the MDrive17 Linear motor is 50 lbs (22.7 kg). Do not exceed this rating!

 **WARNING:** The ACME Screw **MUST NOT** deflect more than ± 1 degree perpendicular to the motor face. Additional support for radial loads may be required!

MDI17 ACME Screws	
Screw	Travel/Full Step - Inches (mm)
A	0.00125 (0.3175)
B	0.000625 (0.015875)
C	0.0003125 (0.079375)
D	0.00015625 (0.00396875)

Table 1.5: ACME Screws for the MDI17 Linear Actuator

General Specifications

Input Voltage (+V)

Range +12 to +48 VDC

Analog Input

Resolution 10 Bit
Voltage Range 0 to +5 Volts

Programmable I/O

Number 4
Interface Type Open Collector
Voltage Range 0 to +24 VDC
Output Sink Current 700 mA
Protection Over Temp., Short Circuit, Inductive Clamp

Communication

Protocol RS-485, Full/Half Duplex SelecTable 1.
BAUD Rate 4800, 9600, 19.2k, 38.0k, 115.2k

Motion

Microstep Resolution (Open Loop Configuration)

Number of Settings 14
Steps per Revolution 400, 800, 1000, 1600, 2000, 3200, 5000
6400, 10000, 12800, 25000, 25600, 50000
51200

Microstep Resolution (Closed Loop Configuration)

Steps per Revolution (Fixed) 51200

Encoder (Optional)

Type Internal, Magnetic
Resolution 512 Lines/2048 counts per Revolution

Counters

Type Position(C1), Encoder (C2)
Resolution 32 Bit
Edge Rate (Max) 5 MHz

Velocity

Range $\pm 5,000,000$ Steps per Second
Resolution 1 Step per Second

Acceleration/Deceleration

Range 1.5×10^9 Steps per Second²
Resolution 90.9 Steps per Second²

General Specifications

Software

Program and Data Storage	Non-Volatile
User Program Space	767 Bytes
User Registers	4 - 32 Bit
Math Functions	+, -, x, ÷, <>, =, <, <=, >, >=, AND, OR, XOR, NOT
Branch Functions	Branch & Call (Conditional)

Predefined I/O Functions

Inputs	Home, Limit +, Limit -, Go, Stop, Pause, Jog +, Jog -, Analog Input
Outputs	Moving, Fault
Trip Functions	Input, Position
Party Mode Node Addresses	62
Encoder Functions	Stall Detect, Position Maintenance, Find Index

Protection

Types	Thermal
-------------	---------

Power Supply Requirements

Each MDrive will require a maximum power supply current of 2A. Actual power supply current will depend upon the load and duty cycle.

Recommended IMS Power Supplies

Listed below are the power supplies recommended for use with both voltage ranges of the MDrive17 Motion Control.

Unregulated Linear Supply

IP404(MDI17)

Input Specifications

AC Input Voltage Range	102-132VAC/Optional 240VAC
Frequency	50-60Hz

Output Specifications

Voltage (Nominal - No Load)	40 VDC
Current (Peak)	4 Amps
Current (Continuous)	2 Amps

Unregulated Switching Supply

ISP200-4(MDI17)

Input Specifications

AC Input Voltage Range	102-132VAC/Optional 240VAC
Frequency	50-60Hz

Output Specifications

Voltage (Nominal - No Load)	45 VDC
Current (Peak)	3 Amps
Current (Continuous)	1.5 Amps

Thermal Specifications

Because the MDrive consists of two core components, a drive and a motor, close attention must be paid to the thermal environment where the device is used. The following maximum temperatures apply to the MDrive17:

Heatsink Temperature

Max	85°C
-----------	------

Motor Temperature

Max	100°C
-----------	-------

Section 1.3

Introduction to the MDrive23 Motion Control

Introduction to the MDrive23 Motion Control

The MDrive23 Motion Control offers the system designer a low-cost, intelligent motion controller integrated with a NEMA 23 high torque stepping motor and a +12 to +48 VDC microstepping drive.

The MDrive23 Motion Control adds a versatile array of functions by combining a complete programmable motion controller with our already compact and cost effective standard MDrive23, adding little cost and no increase in size. Standard offerings include four 5 to 24 volt programmable I/O points, one 10-bit 0 to 5 volt analog input, 0 to 5 MHz step clock rate, microstep resolution up to 51,200 steps per revolution and a full featured easy-to-program instruction set.

The MDrive23 Motion Control communicates using the RS-485 communications protocol, this allows for point-to-point or multidrop communications using one communications port. Addressing and hardware support up to 62 MDrive nodes in a system. The communications BAUD rate is software selectable and ranges from 4.8 kbps to 115 kbps.

The MDrive23 is also available with an optional closed loop control. The closed loop configuration adds a 512 line (2048 count) internal magnetic rotary encoder with index mark without increasing the length of the unit. Closed loop configuration adds position maintenance, stall detection and find index mark.

Available motor configurations include: single shaft, double shaft with control knob, and long life ACME screw linear actuator. Rotary versions are available in three stack lengths: 18, 22 & 31. Interface connections are accomplished using either a 7 position terminal block or optional 12" flying leads.

Feature Summary

- Integrated Microstepping Drive/Motion Controller with Optional Encoder/NEMA 23 High Torque Stepping Motor
- +12 to +48VDC Input Voltage
- Low Cost
- Extremely Compact
- Available Configurations: Single Shaft*, Linear Actuator, Integral Encoder*, Double Shaft with Knob for Manual Positioning*
- Three Motor Stack Lengths Available*
- Single Power Supply
- Microstep Resolution up to 51,200 Steps Per Revolution
- Open Loop or Optional Closed Loop Control
- Programmable Motor Run and Hold Current Settings
- Four 5 to 24 VDC Programmable I/O Points
- One Analog 10 Bit, 0 to 5 Volt Analog Input
- 0 to 5 MHz Step Clock Rate, Selectable in 0.59 Hz Increments
- RS-485 Communications Protocol
- Communications BAUD Rate Selectable from 4.8 kbps to 115 kbps
- 62 Software Addresses for Multidrop Communications
- Simple 1 and 2 Character Programming Instructions
- Pluggable Terminal Strip or 12" Flying Lead Interface
- Optional Integrated RS-232 to RS-485 Converter/Communications Cable

*Rotary Motor Only

Section 1.4

MDrive23 Motion Control Specifications

Section Overview

This section contains mechanical, motor and electrical specifications specific to each version of the MDrive23 Motion Control. Shown are:

- Rotary Motor Specifications
- Linear Motor Specifications
- General Specifications
- Power Supply Requirements
- Thermal Specifications

Rotary Motor Specifications

Mechanical Specifications - Dimensions in Inches (mm)

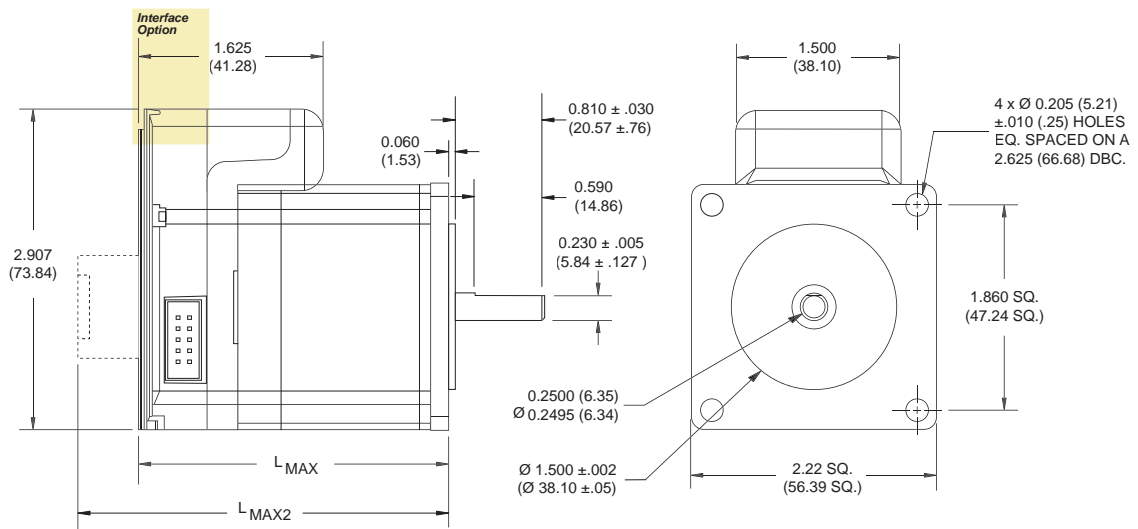

Standard Rotary Motor (L_{MAX})	
Stack	In (mm)
2218	2.632 (66.85)
2222	3.000 (76.20)
2231	3.960 (100.58)

Control Knob (L_{MAX2})	
Stack	In (mm)
2218	3.088 (78.44)
2222	3.537 (89.84)
2231	4.416 (112.17)

Figure 1.8: Rotary MDrive23 Motion Control Mechanical Specifications

MDrive Motion Control 2218 Motor Specs and Speed/Torque Curves

MDI2218	
Holding Torque oz-in (N-cm)	90 (64)
Detent Torque oz-in (N-cm)	3.5 (2.5)
Rotor Inertia oz-in-sec ² (kg-cm ²)	0.0025 (0.18)
Weight (Motor+Driver) oz (gm)	20.1 (569.8)

Table 1.6: Rotary MDI2218 Motor Specifications

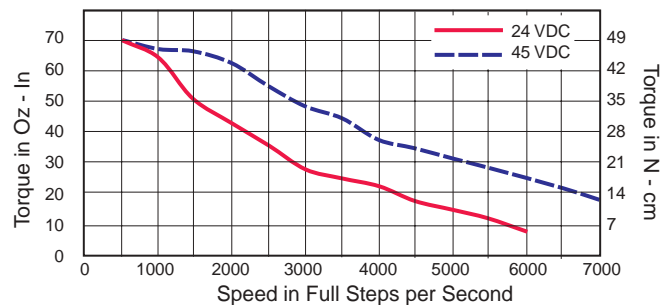

Figure 1.9: Rotary MDrive Motion Control 2218 Speed/Torque Data

MDrive Motion Control 2222 Motor Specs and Speed/Torque Curves

MDI2222	
Holding Torque oz-in (N-cm)	144 (102)
Detent Torque oz-in (N-cm)	5.6 (3.92)
Rotor Inertia oz-in-sec ² (kg-cm ²)	0.0037 (0.26)
Weight (Motor+Driver) oz (gm)	24.4 (691.7)

Table 1.7: Rotary MDI2222 Motor Specifications

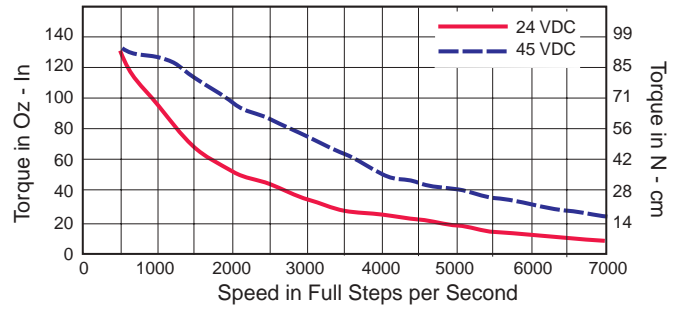

Figure 1.10: Rotary MDrive Motion Control 2222 Speed/Torque Data

MDrive Motion Control 2231 Motor Specs and Speed/Torque Curves

MDI2231	
Holding Torque oz-in (N-cm)	239 (169)
Detent Torque oz-in (N-cm)	9.7 (6.86)
Rotor Inertia oz-in-sec ² (kg-cm ²)	0.0065 (0.46)
Weight (Motor+Driver) oz (gm)	38.5 (1091.5)

Table 1.8: Rotary MDI2231 Motor Specifications

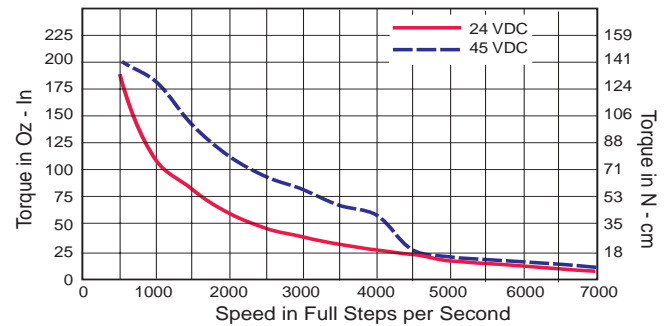

Figure 1.11: Rotary MDrive Motion Control 2231 Speed/Torque Data

Linear Motor Specifications

Mechanical Specifications - Dimensions in Inches (mm)

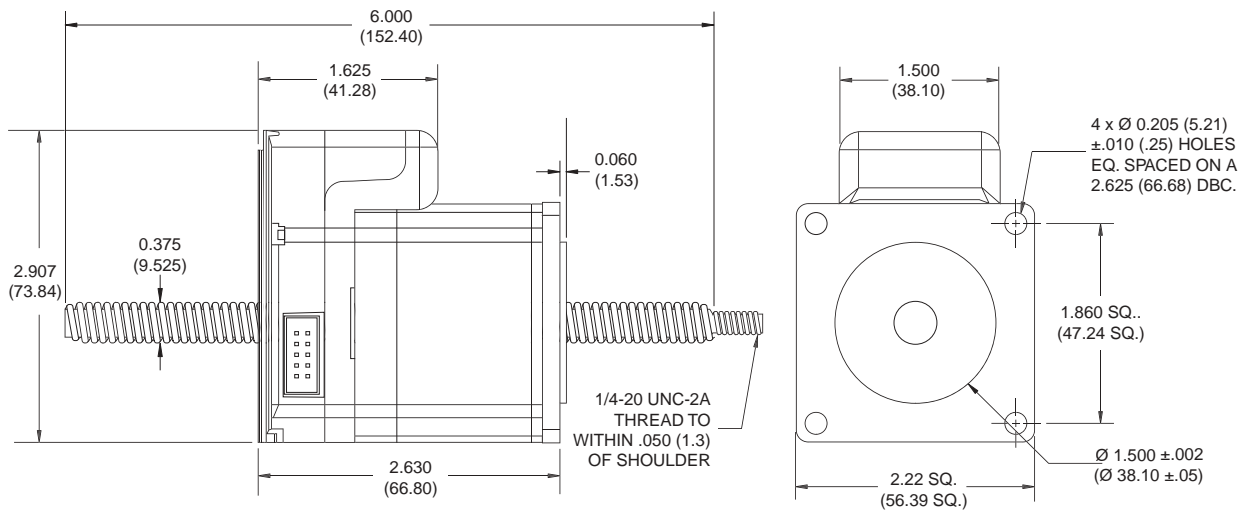

Figure 1.12: Linear Actuator MDrive23 Motion Control Mechanical Specifications

Linear Actuator MDrive Motion Control 2218 Specs and Speed-Force Curves

MDI23 Linear Actuator	
Maximum Thrust lbs (kg)	200 (90.7)
Maximum Screw Deflection	±1°
Backlash inches (mm)	0.005 (0.127)
Weight (Motor+Driver) oz (gm)	20.4 (578.3)

Table 1.9: Linear Actuator MDrive23 Motion Control Motor Specifications

Speed-Force Curve: 24 VDC

Refer to Table 1.10 for screw pitch information

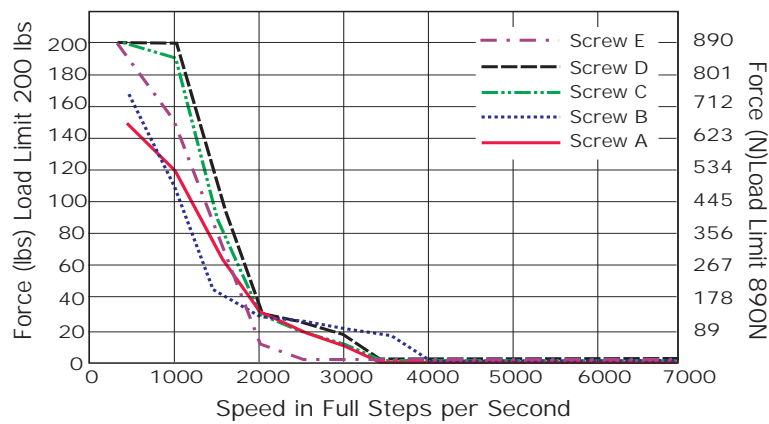

Figure 1.13: Speed-Force Curve - 24VDC (100% Current)

Speed-Force Curve: 45 VDC

Refer to Table 1.10 for screw pitch information

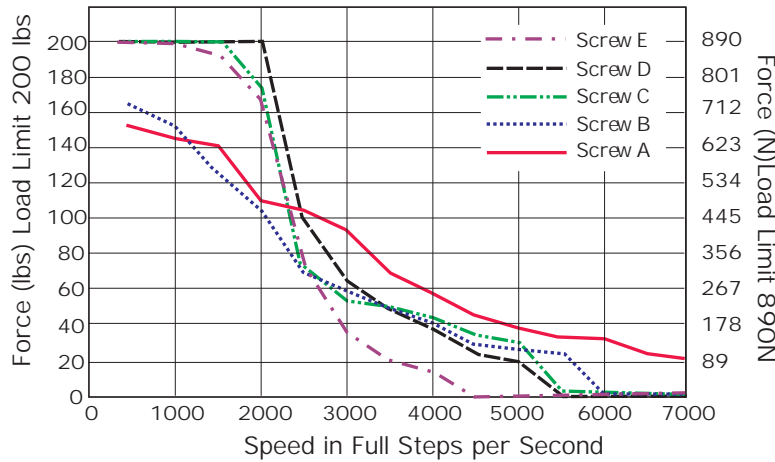



Figure 1.14: Speed-Force Curve - 45VDC (100% Current)

 **WARNING:** The maximum axial load limit for the MDrive23 Linear motor is 200 lbs (90.7 kg). Do not exceed this rating!

 **WARNING:** The ACME Screw **MUST NOT** deflect more than ± 1 degree perpendicular to the motor face. Additional support for radial loads may be required!

MDI23 ACME Screws	
Screw	Travel/Full Step - Inches (mm)
F	0.002 (0.0508)
A	0.001 (0.0254)
B	0.000833 (0.0211582)
C	0.0005 (0.0127)
D	0.0004167 (0.00793750)
E	0.0003125 (0.0079375)

Table 1.10: ACME Screws for the MDI23 Linear Actuator

General Specifications

Input Voltage (+V)

Range +12 to +48 VDC

Analog Input

Resolution 10 Bit
Voltage Range 0 to +5 Volts

Programmable I/O

Number 4
Interface Type Open Collector
Voltage Range 0 to +24 VDC
Output Sink Current 700 mA
Protection Over Temp., Short Circuit, Inductive Clamp

Communication

Protocol RS-485, Full/Half Duplex Selectable
BAUD Rate 4800, 9600, 19.2k, 38.0k, 115.2k

Motion

Microstep Resolution (Open Loop Configuration)

Number of Settings 14
Steps per Revolution 400, 800, 1000, 1600, 2000, 3200, 5000
6400, 10000, 12800, 25000, 25600, 50000
51200

Microstep Resolution (Closed Loop Configuration)

Steps per Revolution (Fixed) 51200

Encoder (Optional)

Type Internal, Magnetic
Resolution 512 Lines/2048 counts per Revolution

Counters

Type Position(C1), Encoder (C2)
Resolution 32 Bit
Edge Rate (Max) 5 MHz

Velocity

Range $\pm 5,000,000$ Steps per Second
Resolution 1 Step per Second

Acceleration/Deceleration

Range 1.5×10^9 Steps per Second²
Resolution 90.9 Steps per Second²

General Specifications

Software

Program and Data Storage	Non-Volatile
User Program Space	767 Bytes
User Registers	4 - 32 Bit
Math Functions	+, -, x, ÷, <>, =, <, <=, >, >=, AND, OR, XOR, NOT
Branch Functions	Branch & Call (Conditional)

Predefined I/O Functions

Inputs	Home, Limit +, Limit -, Go, Stop, Pause, Jog +, Jog -, Analog Input
Outputs	Moving, Fault
Trip Functions	Input, Position
Party Mode Node Addresses	62
Encoder Functions	Stall Detect, Position Maintenance, Find Index

Protection

Types	Thermal
-------------	---------

Power Supply Requirements

Each MDrive will require a maximum power supply current of 2A. Actual power supply current will depend upon the load and duty cycle.

Recommended IMS Power Supplies

Listed below are the power supplies recommended for use with both voltage ranges of the MDrive23 Motion Control.

Unregulated Linear Supply

IP404(MDI23)

Input Specifications

AC Input Voltage Range	102-132VAC/Optional 240VAC
Frequency	50-60Hz

Output Specifications

Voltage (Nominal - No Load)	40 VDC
Current (Peak)	4 Amps
Current (Continuous)	2 Amps

Unregulated Switching Supply

ISP200-4(MDI23)

Input Specifications

AC Input Voltage Range	102-132VAC/Optional 240VAC
Frequency	50-60Hz

Output Specifications

Voltage (Nominal - No Load)	45 VDC
Current (Peak)	3 Amps
Current (Continuous)	1.5 Amps

Thermal Specifications

Because the MDrive consists of two core components, a drive and a motor, close attention must be paid to the thermal environment where the device is used. The following maximum temperatures apply to the MDrive23:

Heatsink Temperature

Max	85°C
-----------	------

Motor Temperature

Max	100°C
-----------	-------

Part 2: Connecting, Configuring and Programming the MDrive Motion Control

Intentionally Left Blank

Section 2.1

Interfacing the MDrive Motion Control

Section Overview

This section will acquaint the user with connecting and using the MDrive Motion Control.

- Layout and Interface Guidelines
- Pin Configuration and Descriptions
- Interfacing Power
- Interfacing RS-485 Communications
- Interfacing Digital I/O
- Interfacing Analog Input

Layout and Interface Guidelines

Logic level cables must not run parallel to power cables. Power cables will introduce noise into the logic level cables and make your system unreliable.

Logic level cables must be shielded to reduce the chance of EMI induced noise. The shield needs to be grounded at the signal source to earth. The other end of the shield must not be tied to anything, but allowed to float. This allows the shield to act as a drain.

Power supply leads to the driver need to be twisted. If more than one driver is to be connected to the same power supply, run separate power and ground leads from the supply to each driver.

Recommended Wiring

The following wiring/cabling is recommended for use with the MDrive Motion Control:

Power

Belden Part# 9740 or equivalent 18 Gauge

Logic Wiring (I/O, Communications)

Wire Size 20-22 AWG

General Practices

The following wire strip length is recommended:

Wire Strip Length 0.250" (6.0 mm)

Pin Configuration and Descriptions

Connector P1			
Pin #	Flying Lead	Function	Description
1	White/Yellow	I/O1	Open Collector I/O Point #1, +5 to +24VDC
2	White/Orange	I/O2	Open Collector I/O Point #2, +5 to +24VDC
3	White/Violet	I/O3	Open Collector I/O Point #3, +5 to +24VDC
4	White/Blue	I/O4	Open Collector I/O Point #4, +5 to +24VDC
5	Green	Analog Input	10 Bit, 0 to 5V Analog Input
6	Black	GND	Ground
7	Red	+V	+12 to +48 VDC Power Supply Input

Table 2.1: P1 Pin Configuration and Description

Connector P2 - 10 Pin Header		
Pin #	Function	Description
1- 5	N/C	Reserved
6	RX+	RS-485 Receive +
7	RX-	RS-485 Receive -
8	TX-	RS-485 Transmit -
9	TX+	RS-485 Transmit +
10	GND	Communications Ground

Table 2.2: P2 Pin Configuration and Description

Interfacing Power

An advantage of the MDrive Motion Control is that only a single +12 to +48VDC unregulated linear or unregulated switching power supply is required to power the control circuitry and motor power.

A maximum of 2A output is required from the supply for each MDrive. Note that the actual power required will be based upon the load and duty cycle.

Wiring should be accomplished using shielded twisted pair Belden Part# 9740 or equivalent 18 Gauge. The shield should be attached to earth at the power supply end and left floating at the MDrive end.

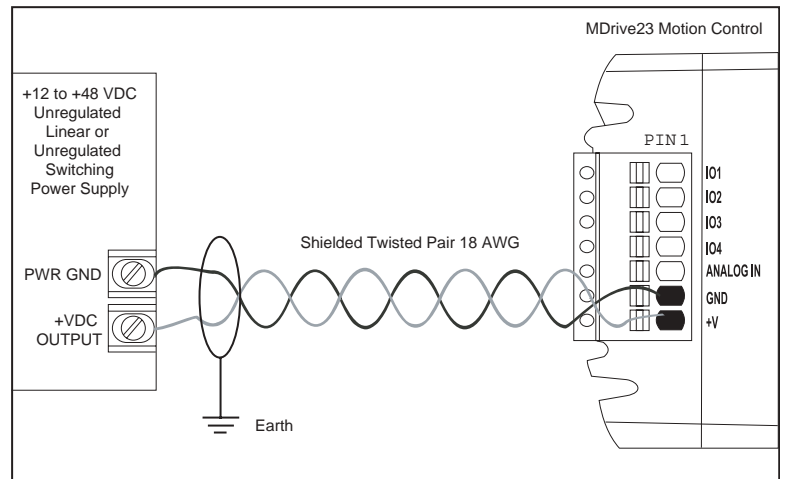

Figure 2.1: Power Supply Interface

Interfacing RS-485 Communications

The MDrive Motion Control communicates to the host using the RS-485 protocol. Communications may be configured as either half or full duplex using the EM (Echo Mode) Instruction. RS-485 may be used in two ways: either to communicate to a single MDrive Motion Control, or to address up to 62 individually named MDrive nodes in a multidrop system.

Single MDrive

Optionally available for the MDrive Motion Control is a communications cable, IMS P/N MD-CC200-000, which has built-in RS-232 to RS-485 conversion circuitry. This will allow you to connect the serial port of your PC directly to the MDrive Motion Control.

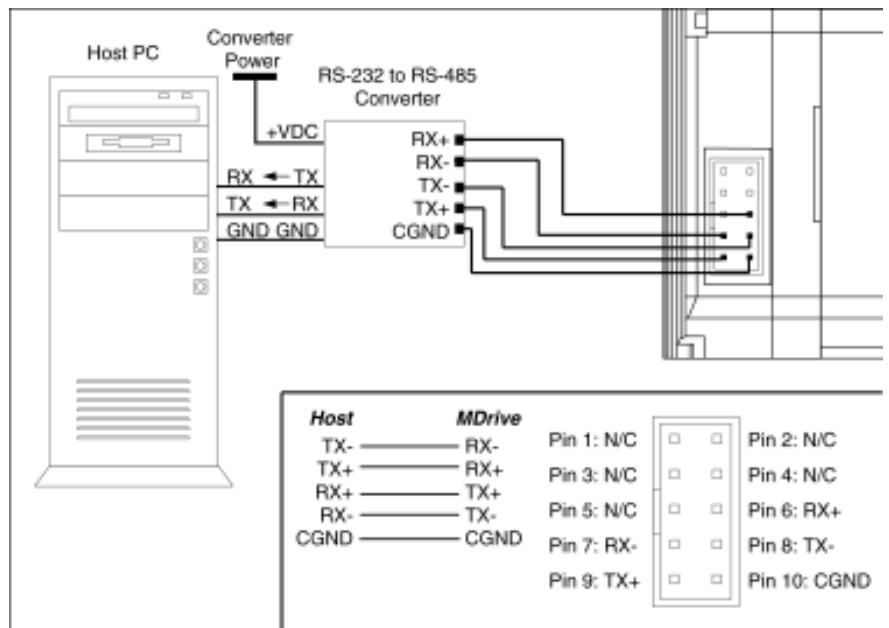

Figure 2.2: RS-485 Interface, Single MDrive Motion Control

Multiple MDrive Motion Control System (Party Mode)

In systems with multiple controllers it is necessary to communicate with the control modules using party mode (PY=1) of operation. The MDrive Motion Control nodes in the system are configured in software for this mode of operation by setting the Party Flag (PY) to True (1). It is necessary for all of the nodes in a system to have this configuration selected. When operating in party mode each MDrive Motion Control in the system will need a unique address, or name, to identify it in the system. This is accomplished by using the software command DN, or Device Name. For example, to set the name of an MDrive to "A" you would use the following command: DN=65 or DN="A" (65 is the ASCII decimal equivalent of uppercase A). The factory default name is "!". The asterisk character "*" is used to issue global commands to every device in the system. See Appendix A for ASCII table.

In setting up your system for party operation the most practical approach would be to observe the following steps:

1. Connect the first MDrive Motion Control to the Host PC configured for Single Mode Operation.
2. Establish communications. Using the command DN name the MDrive Motion Control. This can be any upper or lower case ASCII character or number 0-9.
3. Set the party flag PY=1. Remove power.
4. Connect the next MDrive Motion Control in the system, set the party flag to true.
5. Establish communications with this module using the factory default name "!". This name cannot be reused. Rename and save the new name. Remove power.
6. Repeat the last two steps for each additional MDrive in the system.

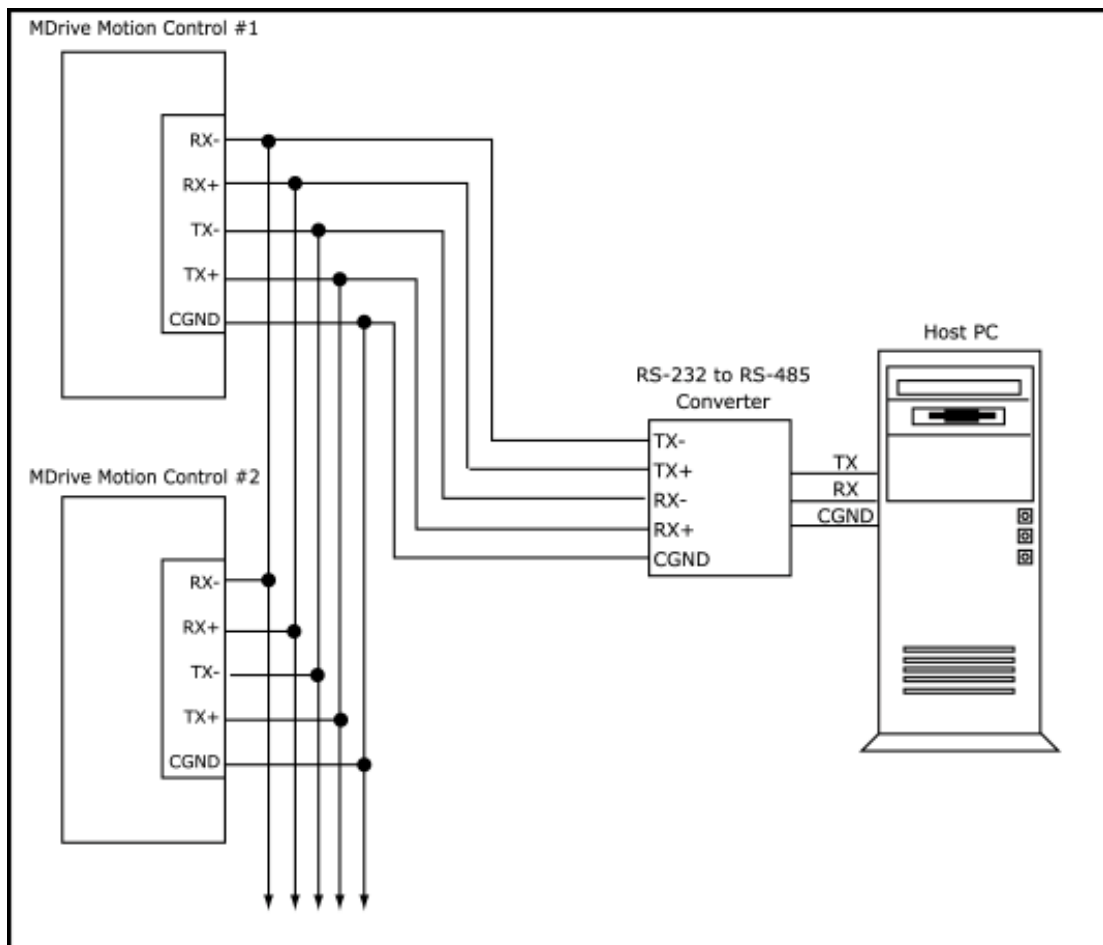

Figure 2.3: RS-485 Interface, Multiple MDrive Motion Control System

Interfacing the Digital I/O

The MDrive Motion Control comes standard with a set of four (4) open collector +5 to +24VDC I/O point which may be programmed individually as either general purpose or dedicated inputs or outputs, or collectively as a group.

The digital I/O may be defined as either active HIGH or active LOW. When the I/O is configured as active HIGH, the level is +5 to +24 VDC and the state will be read/set as a “1”. If the level is 0 VDC then the state will be read/set as “0”. Inversely, if configured as active LOW, then the state of the I/O will be read/set as a “1” when the level is LOW, and a “0” when the level is HIGH. The active HIGH/LOW state is configured by the third parameter of the I/O Setup (S1-4) variable, which is explained further on. The goal of this I/O configuration scheme is to maximize compatibility between the MDrive Motion Control and standard sensors and switches.

The MDrive Motion Control’s I/O scheme is a powerful tool for machine and process control.

Uses of the Digital I/O

The I/O may be utilized to receive input from external devices such as sensors, switches or PLC outputs. When configured as outputs, devices such as relays, solenoids, LED’s and PLC inputs may be controlled from the MDrive Motion Control.

Each I/O point may be individually programmed to any one of 9 dedicated input functions, 3 dedicated output functions, or as general purpose inputs or outputs. The I/O may be addressed individually, or as a group. The active state of the line or group may also be set. All of these possible functions are accomplished with of the I/O Setup Variable (S1-4).

Interfacing Inputs

The MDrive Motion Control inputs may be interfaced to a variety of sinking devices. A single input may be programmed to be a general purpose user input, or to one of nine dedicated input functions. These then may be programmed to have an active state of either HIGH or LOW.

Additionally the inputs may read as a group using the “IN” keyword. This will display as a decimal between 0 and 15 representing the 4 bit binary number. Used thus Input 1 is the Least Significant Bit (LSB) and Input 4 will be the Most Significant Bit (MSB).

Interfacing a Single Input Examples

Input Functions		
S<point>=	Function	Active
0	General Purpose	0/1
1	Home	0/1
2	Limit +	0/1
3	Limit -	0/1
4	GO	0/1
5	Soft Stop	0/1
6	Pause	0/1
7	Jog +	0/1
8	Jog -	0/1
10	Index (encoder only)	0/1

Table 2.3: Input Functions

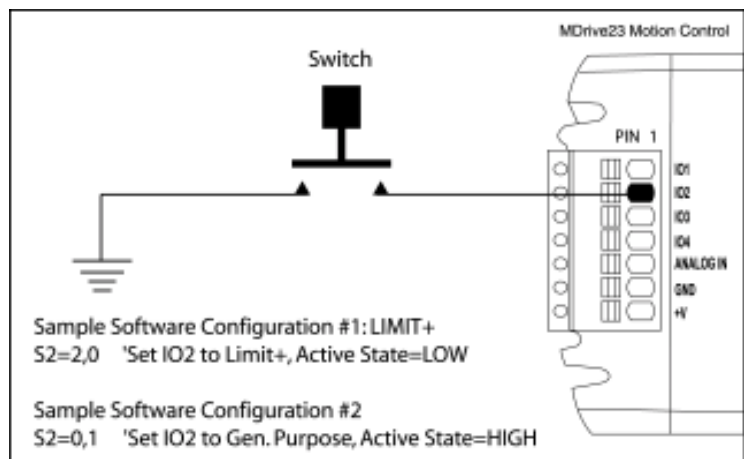

Figure 2.4: Input Interfaced to a Switch

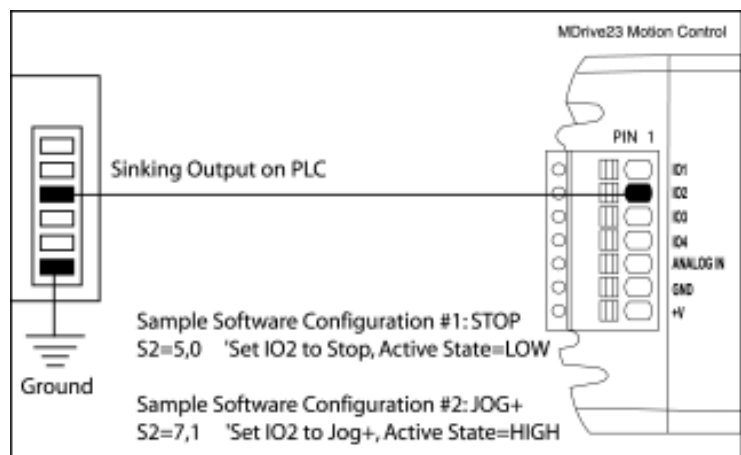

Figure 2.5: Input Interfaced to a PLC

Interfacing Inputs as a Group Example

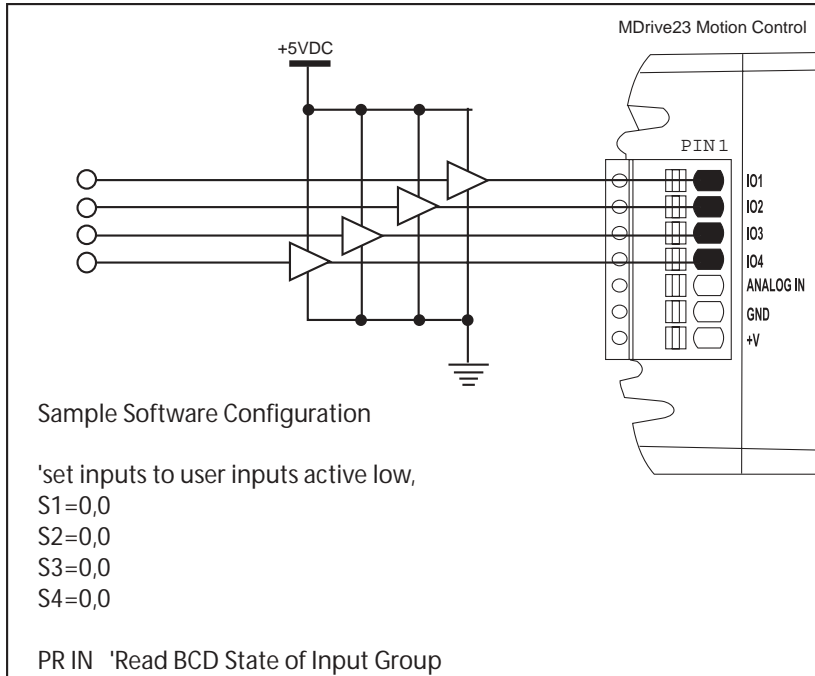

Figure 2.6: TTL Interface to Input Group

Truth Table - I/O Used as a Group				
DEC	IO4	IO3	IO2	IO1
0	0	0	0	0
1	0	0	0	1
2	0	0	1	0
3	0	0	1	1
4	0	1	0	0
5	0	1	0	1
6	0	1	1	0
7	0	1	1	1
8	1	0	0	0
9	1	0	0	1
10	1	0	1	0
11	1	0	1	1
12	1	1	0	0
13	1	1	0	1
14	1	1	1	0
15	1	1	1	1

Table 2.4: I/O Group Truth Table

Interfacing Outputs

The MDrive Motion Control Outputs may be configured as either general purpose or set to one of two dedicated functions, Fault or Moving. These outputs will sink up to 700 mA max and may be connected to +5 to +24VDC. Note that a current limiting resistor may be required to limit the current to 700 mA.

As with the inputs the MDrive Motion Control Outputs may be used singularly or collectively as a group.

Interfacing a Single Output Examples

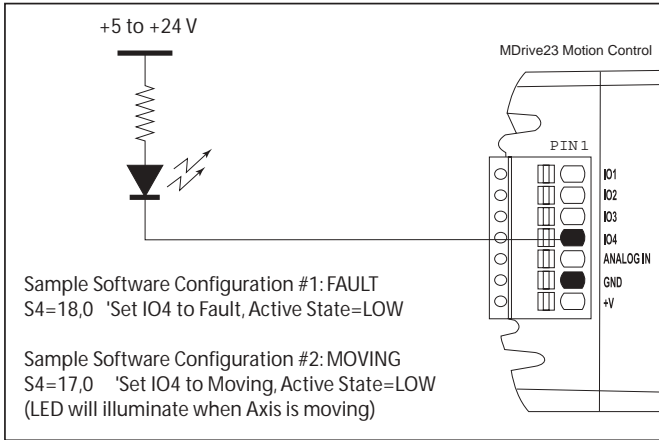

Figure 2.7: Output Interfaced to an LED

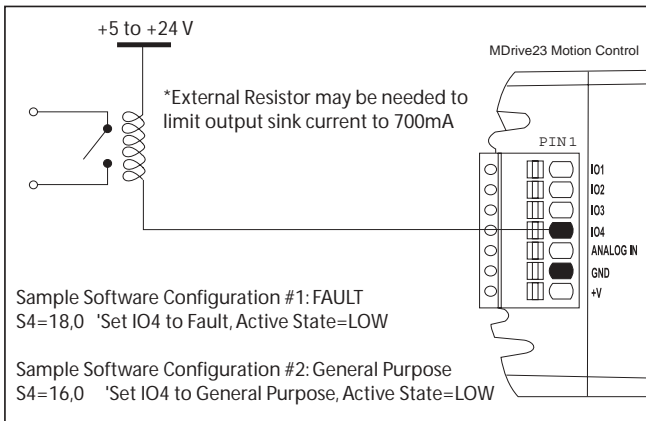

Figure 2.8: Output Interfaced to a Relay

Interfacing Outputs as a Group Example

To write to the outputs as a group the OT instruction is used. This will give you a binary output of 0000 to 1111 from a decimal entry of 0-15. Output 1 will be the Least Significant Bit (LSB), Output 4 will be the Most Significant Bit (MSB).

See Table 2.4 for Truth Table.

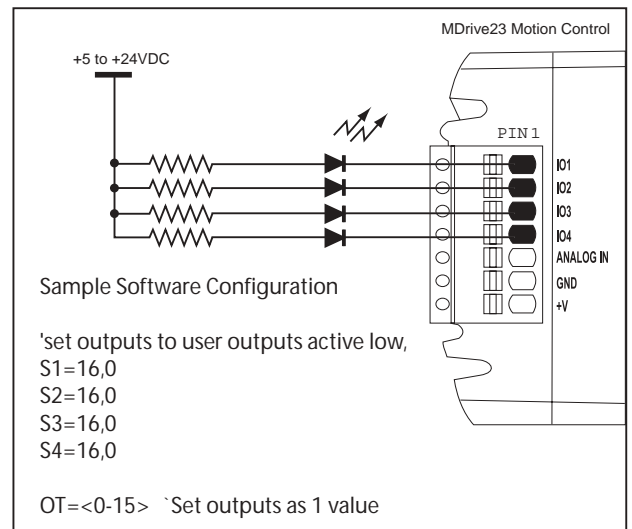

Figure 2.9: Outputs Interfaced to LED's as a Group

Input Functions		
S<point>=	Function	Active
16	General Purpose	0/1
17	Fault	0/1
18	Moving	0/1

Table 2.5: Output Functions

Section 2.2

MDrive Motion Control Software Introduction

Section Overview

This section will acquaint the user with basics of MDrive Motion Control Programming

- Installing IMS Terminal Software
- Upgrading the MDrive Firmware
- The MDrive Program

Installing and Using IMS Terminal

System Requirements

- IBM Compatible PC.
- Windows 95/98 or Windows NT4.0 SP6, Windows 2000 SP2, Windows XP
- 10 MB hard drive space.
- A free serial communications port.

Installation

The IMS Terminal software is a programming/communications interface. This program was created by IMS to simplify programming and upgrading the MDrive Motion Control. The IMS Terminal is also necessary to upgrade the software in your MDrive Motion Control. These updates will be posted to the IMS website at www.imshome.com as they are made available.

To install the IMS Terminal to your hard drive, insert the IMS CD into your CD-ROM Drive. The installation front-end will automatically open.

Follow the on-screen instructions to complete the installation.

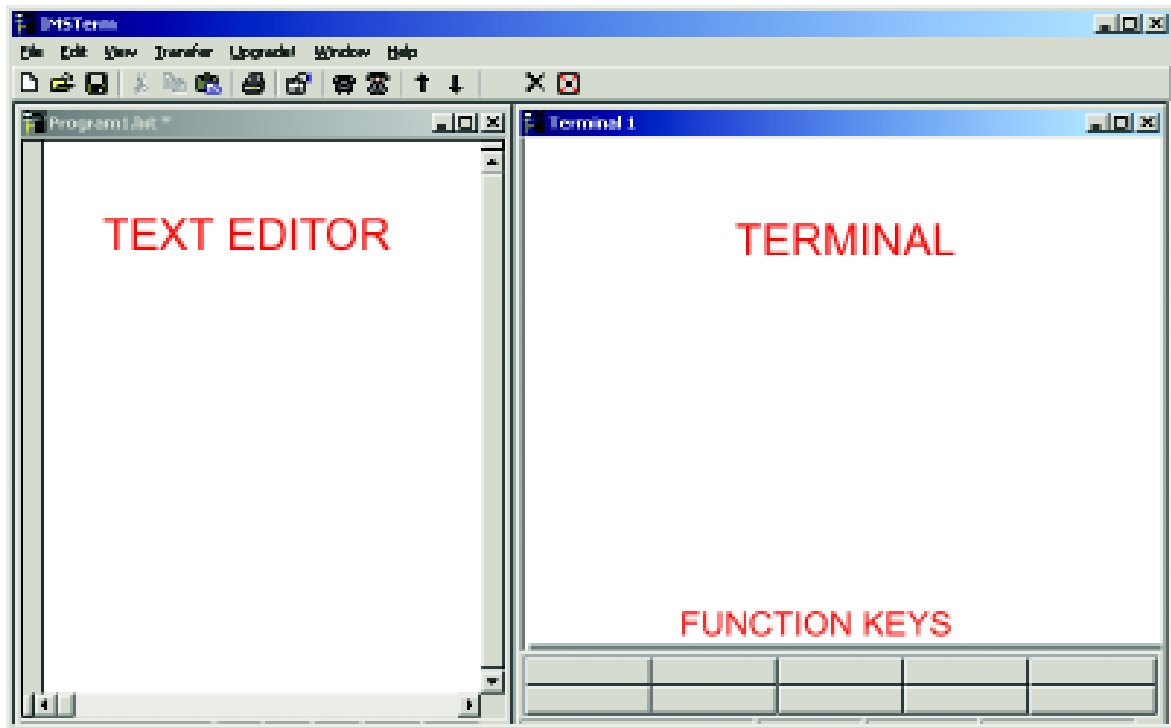

Figure 2.11: IMS Terminal Window

- 1) To open the IMS Terminal select Start > Programs > IMS Terminal > IMS Terminal.
- 2) Click the File Menu Item "Edit>Preferences".
- 3) Click the "Comm Settings" tab.
- 4) Select the Communications Port that you will be using with your MDrive Motion Control.
- 5) The BAUD rate is already set to the MDrive Motion Control default. Do not change this setting until you have established communications with the MDrive Motion Control.
- 6) The "Window Size" settings are strictly optional. You may set these to whatever size is comfortable to you.
- 7) Click "OK". The settings will be automatically saved upon a normal shutdown.
- 8) Apply power to the MDrive Motion Control. A sign-on message should appear in the terminal window.

If you can see this sign-on message then you are up and running! If the sign-on banner does not appear, try using a software reset: hold down the "Ctrl" key and press "C" (^C). If the sign-on banner still does not appear then there may be a problem with either the hardware or software configuration of the MDrive Motion Control or Host PC.

Using the IMS Terminal Software

The IMS Terminal software is an easy to setup and use interface for MDrive Motion Control programming. It is also required to upgrade the firmware in the MDrive Motion Control.

Configuring Communications Settings

The communications settings are configured by means of the "Preferences Dialog". This dialog is accessed through the "Edit > Preferences" menu item or by clicking the "Preferences" icon on the toolbar. The preferences dialog gives the user the ability to set the format for text size, font and color, as well as general communications settings. It is set by default to the optimum communications settings for the MDrive Motion Control. If you change the BAUD rate setting for the MDrive Motion Control, power will have to be cycled for the change to take effect. Ensure that the IMS Terminal preferences are adjusted for the new BAUD settings.

Downloading a Program to the MDrive Motion Control

There are two ways to download programs to the MDrive Motion Control:

- 1] Directly from the text editor window of the IMS Terminal.
- 2] From a text file located on a hard drive or removable disk.

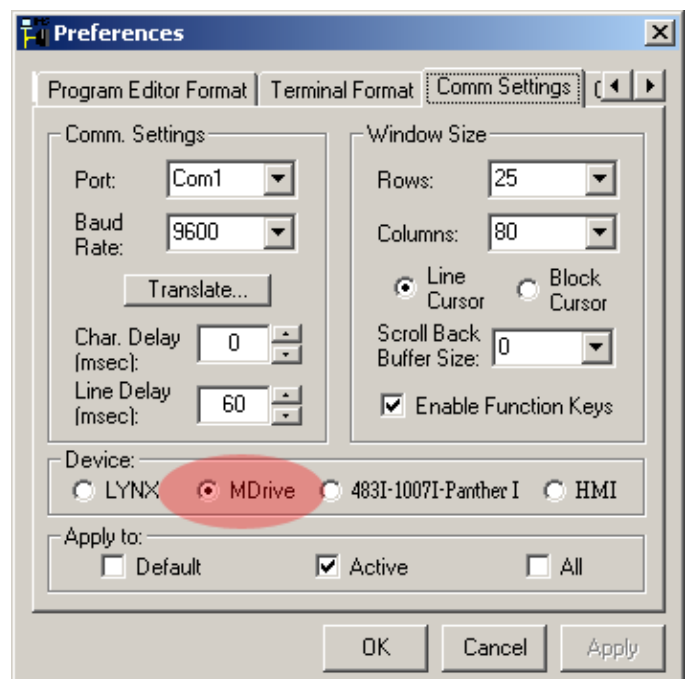

Figure 2.12: IMS Terminal Preferences

To download a program from the text editor window click the menu item "Transfer > Download". The download dialog will open. Select the "Source Type > Edit Window" option, click download. The program will transfer to the MDrive Motion Control.

Programs can be downloaded to the MDrive Motion Control from a text file by selecting "Source Type > File" on the dialog and typing in a drive location:\file name in the "File Name" box on the dialog, or browsing to the file location.

Uploading a Program From the MDrive Motion Control

Programs may also be uploaded from the MDrive Motion Control in two ways:

- 1] Directly to the text editor window of the IMS Terminal.
- 2] To a text file located on a hard drive or removable disk.

To upload a program to the text editor window click the menu item "Transfer > Upload". The upload dialog will open. Select the "Destination Type > Edit Window" option, click "Upload". The program will transfer from the MDrive Motion Control.

Programs may be uploaded from the MDrive Motion Control to a text file by selecting "Destination Type > File" on the dialog and typing in a drive location:\file name in the "File Name" box on the dialog.

Setting the Programmable Function Keys

The IMS Terminal features the capability of programming up to 10 function keys, a feature typically found in more advanced terminal programs. These can be set to provide quick access to commonly used MDrive Immediate mode commands, execute programs, or even hold entire MDrive programs as there is no character limit for each function.

A fly-out dialog can be brought up by clicking the arrow on the right of the function key “Contents” field. This enables the programmer to embed common ASCII control codes in the function key text string.

To access the function key setup dialog, right-click the function key area on the terminal window.

To setup the function keys:

- 1] Enter a caption in the “Caption” text field, this will be displayed on the function button.
- 2] Enter the text string consisting of MDrive Motion Control commands and ASCII control codes. Remember to terminate each command with a line feed (^M) and an appropriate pause time (typically 50 msec, ^p).
- 3] Click “Done” to set the function.

Upgrading the MDrive Motion Control Firmware

- 1] Connect power to the MDrive Motion Control.
- 2] Open the IMS Terminal Software.
- 3] Select the Terminal screen.
- 4] Click the “Upgrade” menu item on the Menu bar.
- 5] Enter 2956102 in the Type Number field.
- 6] Click Next, follow the instructions.
- 7] Cycle power on the MDrive Motion Control.

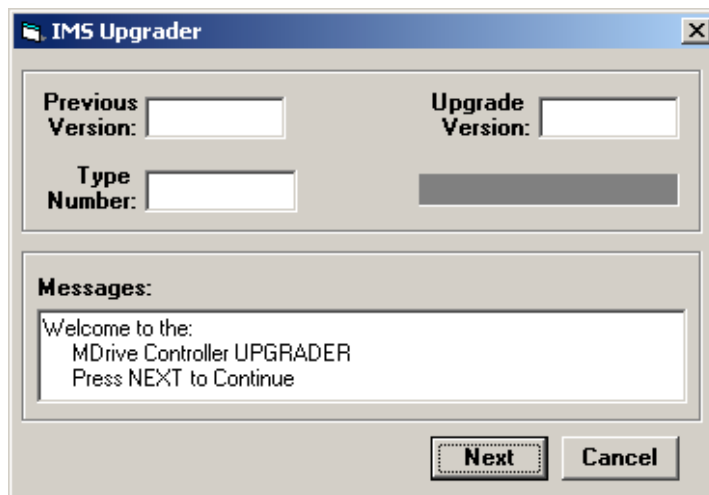

Figure 2.13: IMS Terminal Upgrader Window

MDrive Motion Control Programming

The MDrive programming language consists of simple 1-2 character mnemonics.

Operational Modes

There are two operational modes for the MDrive. Immediate and Program:

- 1] Immediate: Commands are issued and executed directly to the MDrive Motion Control by user entry into the terminal window.
- 2] Program: Commands and processes are run from within an MDrive program. This mode is also used for program entry.

Basic Components of MDrive Motion Control Software

Instructions

An instruction results in an action, there are three types:

Motion

Motion instructions are those that result in the movement of a motor. The syntax of these commands are as such: first type the command followed by a space, and then the velocity or position data. For example, *MA 2000* will move the motor to position 2000.

I/O

An I/O instruction results in the change of parameters or the state of an Input or Output. The syntax of these commands are as such: first type the command followed by a space, then the I/O #, then an equal sign, then the data. Example: *PR I1* will read the state of input 1, *O2=0* will set output 2 to 0.

Program

A program instruction allows program manipulation. The syntax of these vary due to the nature of the command. Some examples would be as such: *PG 100*, this command toggles the system into program mode starting at address 100. *BR LP, IO 21=1*, this command will Branch to a program labeled LP if I/O 21 is true.

System

A system instruction is an instruction that can only be used in immediate mode to perform a system operation such as program execution (EX) or listing the contents of program memory (L). For example: *EX 100* will execute a program located at line 100 of program memory space, or *EX K1* will execute a program labeled K1.

Variables

Variables are labeled data that allow the user to define or manipulate data. These can also be used with the built-in math functions to manipulate data. There are two classes of variables: factory defined and user defined. The syntax for each variable may differ. See Section 6 for usage instructions and examples.

Factory Defined Variables

These variables are predefined at the factory. They cannot be deleted. When an FD (Factory Default) instruction is given, these variables will be reset to their factory default values. There are two types of factory defined variables. They are:

- . Read/Writable: These factory defined variables can have their value altered by the user to effect events inside or outside of a program. For example, A (Acceleration Variable) can be used to set the Acceleration, or P (Position Variable) can be used to set a position reference point.
- . Read Only: These factory defined variables cannot be manipulated by the user, but contain data that can be viewed or used to effect events inside a program. For example, V (Velocity Variable) registers the current velocity of the motor in steps per second.

User Defined Variables

The VA instruction allows the user to assign a 32 bit, 2 character name to a user defined variable.

The restrictions for this command are:

- 1] A variable cannot be named after an MDrive Motion Control Instruction, Variable or Flag.
- 2] The first character must be alpha, the second character may be alpha-numeric.
- 3] A variable is limited to two characters.

With these the user can define a variable to store and retrieve data and perform math functions. When the FD (Factory Defaults) instruction is given, these variables will be deleted! There are two types of user defined variables:

- . Global Variables: Global variables are variables that are defined outside of a program. The benefit to using a global variable is that no user memory is required. For example, the user can define a variable called SP for speed by entering *VA SP* into the terminal. The user can then set that variable to equal the value of the read only variable V (velocity) by entering *SP = V* into the terminal.
- . Local Variables: This type of user defined variable is defined within a program and can only effect events within that program. It is stored in RAM. Examples of this type of variable will be given later in the section. It is worthy of note that a local variable is not static, but is erased and declared again each time a program is executed.

Flags

Flags show the status of an event or condition. A flag will only have one of two possible states: either 1 or 0. Unlike variables, there are only factory defined flags.

Factory Defined Flags

Factory defined flags are predefined at the factory and cannot be deleted. When a FD (Factory Defaults) instruction is given, these flags will be returned to their factory default state. There are two types of factory defined flags:

- . Read/Writable: This type of flag is user alterable. They are typically used to set a condition or mode of operation for the MDrive Motion Control. For example: EE = 1 would enable encoder operation, or EE = 0 would disable the encoder functions.
- . Read Only: Read Only flags cannot be modified by the user. They only give an indication of an event or condition. Typically this type of flag would be used in a program in conjunction with the BR (Branch Instruction) to generate an if/then event based upon a condition. For Example: the following line of code in a program BR SP, MV = 0 would cause a program to branch to a subroutine named "SP" when the MV, the read only moving flag, is false.

Keywords

Keywords are used in conjunction with the PR and IP instructions to indicate or control variables and flags. For instance, PR UV would print the state of all the user-defined variables to the screen. IP would restore all the factory variables from the EEPROM.

Most Commonly Used Variables and Commands

Variables

P

P indicates the position in either steps or encoder counts depending upon the enable/disable state of encoder functions.

- . P takes its reading from C1 (Counter 1) when encoder functions are disabled. The reading is taken from C2 (Counter 2) when encoder functions are enabled.
- . *To read the position, type PR P or PR C1/C2 then hit enter*
- . *To zero the position, type P=0 then hit enter*

VI

Initial velocity in steps per second.

- . *To read the initial velocity, type PR VI then hit enter*
- . *To write to the Initial velocity, type VI=500 then hit enter*

VM

Maximum or final velocity in steps per second.

- . *To read the final velocity, key-in PR VM then hit enter*
- . *To write to the final velocity, key-in VM=5000 then hit enter*

A

Acceleration in steps per second².

- . *To read the acceleration, key-in PR A then hit enter*
- . *To write to the acceleration, key-in A=7500 then hit enter*

D

Deceleration in steps per second².

- . *To read the deceleration, key-in PR D then hit enter*
- . *To write to the deceleration, key-in D=A then hit enter*

Math Functions

Another powerful feature of the MDrive Motion Control is its ability to perform common math functions and to use these to manipulate data.

Addition $K2^\dagger = P + R2$
Subtraction $K3^\dagger = R1 - P$
Multiplication $A = A * 2$
Division $A = A / 2$

[†]User-defined variable used as an example.

Motion Commands

MA

Move to an absolute position relative to a defined zero position.

For example, type the following commands followed by hitting enter:

```
P=0
MA 20000
H
PR P
```

The terminal screen will read 20000

```
MA 3000
H
PR P
```

The screen will echo back 3000.

MR

Move number of steps indicated relative to current position.

For example, type the following commands followed by hitting enter:

```
P=0
MR 20000
H
PR P
```

The terminal screen will read 20000

```
MR 3000
H
PR P
```

Notice the position echoed is 23000 and not 3000.

SL

Move at a constant velocity.

```
SLEW 200000
```

The motor will move at a constant velocity 200000 steps per second.

H

An H (hold) should typically follow any MA or MR commands in a program so that program execution is suspended until motion is complete.

(Note: There are circumstances where you may not want to hold up program execution.)

Below is a usage example.

```
PG 100      `enter program mode at address 100
LB M1       `label program M1
MR 20000    `set motion mode to relative, move relative 20000 steps
H           `hold until motion completes
-20000      `move relative -20000 steps
H           `hold until motion completes
E           `end program
PG          `exit program mode
```

I/O Commands

S < 1 - 4 >

This command configures the Type and Active state of I/O points 1-4.

Using the PR command to read IO parameters

Read IO1 Setup – “PR S1”

Read IO2 Setup – “PR S2”

Setting the I/O parameters

Set IO 3 parameters – “S3=0,1” Sets IO3 as a General Purpose Input, Active High

For example: To set IO4 as a Jog+ Input/Active Low

S4 =7,0

I < 1 - 4 >

Used to read the state of an individual input.

PR I1 will read the state of input 1 and display it to the terminal window.

BR K5, I2=0 will branch to the program address labeled K5 when Input 2 is LOW

I N

Used to read the decimal equivalent of the 4 bit binary number represented by all 4 inputs collectively. Note the Input 4 is the Most Significant Bit.

PR IN will print the decimal value of the inputs.

O < 1 - 4 >

Used to set the state of an output.

O2=1 will set Output 2 TRUE

O T

Used to set the 4 bit binary equivalent of the decimal number represented by all 4 outputs collectively. Note the Output 4 is the Most Significant Bit.

OT=13 will set the outputs to 1101

System Instructions

The following System Instructions will be used frequently.

CP

The CP Instruction is used to clear Program memory space.

FD

The FD Instruction is used to return the MDrive Motion Control to its factory default state.

Program Instructions

PG

This instruction toggles the MDrive Motion Control into or out of program mode.

Switch to program mode at address 200

PG 200

xxxxx

Program starting at address 200

xxxxx

xxxxx

Switch out of program mode

PG

LB

The MDrive Motion Control also offers the user the convenience of naming programs, subroutines and processes to ease in branching from one part of a program to another, or calling a subroutine.

These labels, once set, will act as pointers to locations in program memory space.

The LB, or Label Instruction, allows the user to assign a 2 character name to a program or branch process within a program or subroutine.

The restrictions for this command are:

- 1] A label cannot be named after a MDrive Motion Control Instruction, Variable or Flag.
- 2] The first character must be alpha, the second character may be alpha-numeric.
- 3] A label is limited to 2 characters.
- 4] A program labeled SU will run on power-up

Please Note: Any program labeled “SU” will execute on power-up.

Switch to program mode at address 200	PG 200
Label command will name the program	LB K1
	xxxx
Program named by LB command	xxxx
	xxxx
Switch out of program mode	PG

BR

Used to branch conditionally or unconditionally to a routine.

Switch to program mode at address 200	PG 200
Label command will name the program	LB K1
	xxxx
Program named by LB command	xxxx
	xxxx
Unconditional branch to Program 1	BR K1
Switch out of program mode	PG

E

Designates the end of a program.

Switches to program mode at address 200	PG 200
Label command will name the program	LB K1
	xxxx
Program named by LB command	xxxx
	xxxx
Unconditional branch to K1	BR K1
Designates the end of the program	E
Switches out of program mode	P

H

Delays program execution in milliseconds.

Switches to program mode at address 200	PG 200
Label command will name the program	LB K1
	xxxxx
Program named by LB command	xxxxx
	xxxxx
Delay 2 seconds between re-execution of program	H 2000
Unconditional branch to K1	BR K1
Designates the end of the program	E
Switches out of program mode	P

PRINT

Outputs specified text and parameter values to a terminal or terminal software on a Host PC.

Switches to program mode at address 200	PG 200
Label command will name the program	LB K1
	xxxxx
Program named by LB command	xxxxx
	xxxxx
Prints text in quotes and then POS	PR "Position = " P
Delay 2 seconds between re-execution of program	H 2000
Unconditional branch to K1	BR K1
Designates the end of the program	E
Switches out of program mode	PG

VAR

Command used to define a variable with 8 alphanumeric characters.

Switches to program mode at address 200	PGM 200
Define a variable named CT for Count	VAR CT
Label command will name the program	LBL K1
	xxxxx
Program named by LB command	xxxxx
	xxxxx
Prints text in quotes and then POS	PRINT "Position = " P
Delay 2 seconds between re-execution of program	H 2000
Unconditional branch to K1	BR K1
Designates the end of the program	E
Switches out of program mode	PGM

Section 2.3

MDrive Motion Control Command Set Summary

Setup Instructions, Variables and Flags

Mnemonic	Function	Unit	Range	Syntax Example
BD	Communications BAUD Rate	BAUD	48, 96, 19, 38, 11	BD=<baud>
DE	Enable/Disable Drive	-	1/0	DE=<1/0>
DN	Device Name	Character	a-z, A-Z, 0-9	DN=<char>
EM	Echo Mode 0 (def)=Full Duplex, 1=Half Duplex	Mode	0/1	EM=<mode>
IP	Initial Parameters from EEPROM	-	-	IP
PY	Enable/Disable Party Mode	Mode	1/0	PY=<mode>
UG	Upgrade Firmware	Code	2956102	IMS Term. Upgrader

Miscellaneous Instructions, Variables and Flags

Mnemonic	Function	Unit	Range	Syntax Example
AL	All Parameters, Used with PR (Print)	-	-	PR AL
BY	BSY Flag 1=Prog. Running	-	0/1	PR BY
PR	Print Selected Data and/or Text	-	-	PR <data/text string>
R1	User Register 1	Number	Signed 32 bit	R1=<number>
R2	User Register 2	Number	Signed 32 bit	R2=<number>
R3	User Register 3	Number	Signed 32 bit	R3=<number>
R4	User Register 4	Number	Signed 32 bit	R4=<number>
VR	Firmware Version	Number	-	PR VR
UV	Read User Variables	-	=	PR UV

Motion Instructions, Variables and Flags

Mnemonic	Function	Unit	Range	Syntax Example
(-)	Do Previously Set Mode to/at This Value	per mode		-<number>
A	Set Acceleration	Steps/Sec ²	100000000	A=<accel>
D	Set Deceleration	Steps/Sec ²	100000000	D=<decel>
HC	Set Hold Current	% (Percent)	0 to 100	HC=<percent>
HT	Set Hold Current Delay Time	milliseconds	0-65000	HT=<msec>
MA	Set Mode and Move to Abs. Position	±Position	Signed 32 bit	MA <±pos>
MD	Motion Mode Setting	-	-	-
MR	Set Mode and Move to Relative Position	±Distance	Signed 32 bit	MR <±dist>
MS	Set Microstep Resolution	Microsteps/step	MSEL Table	MS=<param>
MT	Motor Settling Delay Time	milliseconds	0-65000	MT=<msec>
MV	Moving Flag	-	-	PR MV
RC	Set Run Current	% (Percent)	1 to 100	RC=<percent>
SL	Set Mode and Slew Axis	Steps/sec	±5000000	SL=<velocity>
V	Read Current Velocity	Steps/sec	±5000000	PR V
VI	Set Initial Velocity	Steps/sec	1-5000000	VI=<velocity>
VM	Set Maximum Velocity	Steps/sec	1-5000000	VM=<velocity>

I/O Instructions, Variables and Flags

Mnemonic	Function	Unit	Range	Syntax Example
D1	Set Input 1 Digital Filtering	Milliseconds	0-255	D1=<time>
D2	Set Input 2 Digital Filtering	Milliseconds	0-255	D2=<time>
D3	Set Input 3 Digital Filtering	Milliseconds	0-255	D3=<time>
D4	Set Input 4 Digital Filtering	Milliseconds	0-255	D4=<time>
D5	Set Input 5 Digital Filtering	Milliseconds	0-255	D5=<time>
I1	Read Input 1	-	0/1	PR I1, BR I1,<cond>
I2	Read Input 2	-	0/1	PR I2, BR I2,<cond>
I3	Read Input 3	-	0/1	PR I3, BR I3,<cond>
I4	Read Input 4	-	0/1	PR I4, BR I4,<cond>
I5	Read Input 5 (Analog)	-	0-1024	PR I5, BR I5,<cond>
I6	Read Encoder Index Mark Low true			
IN	Read Inputs 1-4 as One Value	data	0-15	PR IN
O1	Set Output 1 to Logic State	-	0/1	O1=<1/0>
O2	Set Output 2 to Logic State	-	0/1	O2=<1/0>
O3	Set Output 3 to Logic State	-	0/1	O3=<1/0>
O4	Set Output 4 to Logic State	-	0/1	O4=<1/0>
OT	Write Data to Outputs 1-4 as One Value	data	0-15	OT=<data>
S1	Setup IO Point 1	Type, Active	Type Table, 0/1	S1=<type>,<active>
S2	Setup IO Point 2	Type, Active	Type Table, 0/1	S2=<type>,<active>
S3	Setup IO Point 3	Type, Active	Type Table, 0/1	S3=<type>,<active>
S4	Setup IO Point 4	Type, Active	Type Table, 0/1	S4=<type>,<active>
TI	Trip on Input	-	-	TI <input>,<addr>
TE	Trip Enable	See Table	<1-4>	TE=<num>

Program Instructions, Variables and Flags

Mnemonic	Function	Unit	Range	Syntax Example
BR	Branch (Conditional/Unconditional)	-	-	BR <addr>, <cond>
CL	Call Subroutine (Conditional/Unconditional)	-	-	CL <addr>, <cond>
CP	Clear Program	Address	1-767	CP <addr>
DC	Decrement Variable	-	-	DC <var/ureg>
E	End Program Execution	-	-	E
EX	Execute Program at Address Using Selected Trace Mode		1-767	EX <addr>, <mode>
H	Hold Prog. Execution Blank/0=Motion stops	milliseconds	Blank(0)/1-65000	H=<msec>
IC	Increment Variable	-	-	IC <var>
L	List Program	Address	1-767	L <addr>
LB	Create a Program Address Label Name			
OE	On Error Handler 0=Disabled	Address	0/1-767	OE <addr>
PG	Start Program Entry at Specified Address	-	Blank/1-767	PG <addr>
RT	Return from Subroutine	-	-	RT
S	Save to EEPROM	-	-	S
VA	Create A User Variable Name			
UV	Read User Variables	-	-	PR UV

Position Related Instructions, Variables and Flags

Mnemonic	Function	Unit	Range	Syntax Example
C1	Set Counter 1	Motor Counts	Signed 32 bit	C1=<counts>
HM	Home to Home Switch	Type	1-4	HM <type>
P	Set/Read Position	Motor/Encoder Counts	Signed 32 bit	P=<counts>
PC	Read Captured Position at Trip			
TP	Trip on Position	Position	-	TP <pos>, <addr>
TE	Trip Enable	See Table	<1-4>	TE=<num>

Encoder Related Instructions, Variables and Flags

Mnemonic	Function	Unit	Range	Syntax Example
C2	Set Counter 2	Encoder Counts	Signed 32 bit	C2=<counts>
DB	Set Encoder Deadband	Encoder Counts	0-65000	DB=<counts>
EE	Enable/Disable Encoder Functions	-	1/0	EE=<1/0>
HI	Home to Encoder Index	Type	1-4	HI=<type>
I6	Read Encoder Index Mark	-	-	I6
SF	Set Stall Factor	Encoder Counts	0-65000	SF=<counts>
SM	Set Stall Mode	0=Stop Motor/1=Don't Stop	1/0	SM=<mode>
ST	Stall Flag	-	0/1	PR ST

Mathematical Functions

Symbol	Function
+	Add Two Variables and/or Flags
-	Subtract Two Variables and/or Flags
*	Multiply Two Variables and/or Flags
/	Divide Two Variables and/or Flags
<>	Not Equal
=	Equal
<	Less Than
<=	Less Than and/or Equal
>	Greater Than
>=	Greater Than and/or Equal
&	AND (Bitwise)
	OR (Bitwise)
^	XOR (Bitwise)
!	NOT (Bitwise)

Section 2.4

MDrive Motion Control Command Set

MNEMONIC	FUNCTION	TYPE
A	Acceleration	Motion Variable

DESCRIPTION

The A Variable sets the peak acceleration that will be reached by the MDrive in steps per second².

USAGE	UNITS	RANGE	DEFAULT
A=<accl>	Steps/sec ²	0 to 1525878997	1000000

EXAMPLE:

A=20000 'set acceleration to 20000 steps/sec²
A=D 'set acceleration equal to deceleration

RELATED COMMANDS: D

MNEMONIC	FUNCTION	TYPE
AL	Retrieve All Parameters	Variable

DESCRIPTION

The AL variable is used with the PR (PRINT) instruction to print the value/state of all variables and flags to the terminal program.

USAGE
PR AL

RELATED COMMANDS: PR

MNEMONIC	FUNCTION	TYPE
BD	BAUD Rate	Setup Variable

DESCRIPTION

This variable sets the baud rate for serial communications with the MDrive. It sets the rate for the RS-485 interface. The baud rate is set by indicating the first two digits of the desired rate as shown in the range section below.

In order for the new BAUD rate to take effect, the user must issue the S (SAVE) instruction and then reset the MDrive. When the MDrive is reset, it will communicate at the new BAUD rate.

48 = 4800 bps, 96 = 9600 bps, 19 = 19200 bps, 38 = 38000 bps, 11 = 115200 bps

USAGE	UNITS	RANGE	DEFAULT
BD=<baud>	bits per second	48, 96, 19, 38, 11	9600 bps

EXAMPLE:

BD=96 'set communications BAUD rate to 9600 bps

RELATED COMMANDS: —

MNEMONIC	FUNCTION	TYPE
BR	Branch	Program Instruction

DESCRIPTION

The branch instruction can be used to perform a conditional or unconditional branch to a routine in an MDrive program. It can also be used to perform loops and IF THEN logic within a program.

There are two parameters to a branch instruction. These are used to perform two types of branches:

Conditional Branch

This type of branch first specifies an address or process label where program execution should continue if the second parameter, the condition, is true. The condition parameter may include flags as well as logical functions that are to be evaluated.

Unconditional Branch

In this type of branch the second parameter is not specified, then the execution will continue at the address specified by the first parameter.

USAGE

BR <addr/label, cond>

EXAMPLE:

BR 256, I2 'Branch to program line 256 if Input 2 is TRUE

BR 120 'Unconditional Branch to program line 120

BR JC, I1=1 'Branch to process labeled JC if input 1 is True

RELATED COMMANDS: —

MNEMONIC	FUNCTION	TYPE
BY	Busy Flag (Read Only)	Motion Flag

DESCRIPTION

This read only status flag will indicate whether or not the axis is moving.

USAGE

PR BY

UNITS

—

RANGE

0/1

DEFAULT

0

EXAMPLE:

PR BY 'read the state of the busy flag

RELATED COMMANDS: PR

MNEMONIC	FUNCTION	TYPE
C1	Set Counter 1 (Motor Counts)	Motion Variable

DESCRIPTION

This variable contains the raw count representation of the clock pulses sent to the motor drive.

USAGE

C1=<counts>

UNITS

Motor Counts

RANGE

-2147483648 to 2147483647

DEFAULT

0

EXAMPLE:

C1=20000 'Set Counter 1 to 20000 motor counts

PR C1 'Print the value of C1 to the terminal screen

RELATED COMMANDS: C2, P

MNEMONIC	FUNCTION	TYPE
C2	Set Counter 2 (Encoder Counts)	Motion Variable

DESCRIPTION

This variable contains the raw count representation of the integral 512 line encoder.

USAGE	UNITS	RANGE	DEFAULT
C2=<counts>	Encoder Counts	-2147483648 to 2147483647	0

EXAMPLE:

C2=512 ‘Set Counter 2 to 512 encoder counts
PR C2 ‘Print the value of C2 to the terminal screen

RELATED COMMANDS: C1, EE, P

MNEMONIC	FUNCTION	TYPE
CL	Call Subroutine	Program Instruction

DESCRIPTION

This function can be used to invoke a subroutine within a program. This allows the user to segment code and call a subroutine from a number of places rather than repeating code within a program.

There are two parameters to the CL instruction. The first specifies the program address or label of the subroutine to be invoked if the second parameter, the condition, is true. If the second parameter is not specified, the subroutine specified by the first parameter is always invoked. The condition parameter can include flags as well as logical functions that are to be evaluated.

The subroutine should end with a RT (RET) instruction. The RT instruction will cause program execution to return to the line following the CL instruction.

USAGE

CL <addr/label, cond>

EXAMPLE:

CL 256, I1=1 ‘Call subroutine at program line 256 if Input 1 is TRUE
CL JK ‘Call subroutine labeled JK

RELATED COMMANDS: RT

MNEMONIC	FUNCTION	TYPE
CP	Clear Program	Program Instruction

DESCRIPTION

This instruction will clear the program space in the EEPROM as specified by the instruction parameter. Programs are stored directly to the EEPROM and executed from there.

USAGE

CP <addr/label>

EXAMPLE:

CP 256 ‘Clear program space beginning at line 256 to the end of program space
CP ‘Clear all of program space

RELATED COMMANDS: —

MNEMONIC	FUNCTION	TYPE
D1-D5	Digital Input Filtering	I/O Variable

DESCRIPTION

This variable will set the digital filtering to be applied to the selected input 1 - 5. The input must be stable for “time” amount of milliseconds before a change in state is available.

USAGE	UNITS	RANGE
D <1-5>=<time>	Milliseconds	0 to 255

EXAMPLE:

D1=0 ‘no debounce
D4=150 ‘150 mSec of filtering

RELATED COMMANDS: I1-I5

MNEMONIC	FUNCTION	TYPE
D	Deceleration	Motion Variable

DESCRIPTION

The D variable sets the peak deceleration of the MDrive in steps per second².

USAGE	UNITS	RANGE	DEFAULT
D=<decl>	Steps/sec ²	0 to 1525878997	1000000

EXAMPLE:

D=20000 ‘set acceleration to 20000 step/sec²
D=A ‘set deceleration equal to acceleration

RELATED COMMANDS: A,

MNEMONIC	FUNCTION	TYPE
DB	Set Encoder Deadband	Setup Variable

DESCRIPTION

This variable defines the + and - length of the encoder deadband in encoder counts.
When the encoder is enabled, a move is not completed until motion stops within DB.

USAGE	UNITS	RANGE	DEFAULT
DB=<counts>	Encoder Counts	0 to 65000	1

EXAMPLE:

DB=5 ‘Set Encoder Deadband to ± 5 encoder counts

RELATED COMMANDS: EE

MNEMONIC	FUNCTION	TYPE
DC	Decrement Variable	Program Instruction

DESCRIPTION

The DC instruction will decrement the specified variable by one.

USAGE
DC <var>

EXAMPLE:

DC R1 ‘Decrement User Register 1

RELATED COMMANDS: IC

MNEMONIC	FUNCTION	TYPE
DE	Drive Enable Flag	Setup Flag

DESCRIPTION

The DE flag enables or disables the drive portion of the MDrive Motion Control.

USAGE

DE= <0/1>

DEFAULT

1 (Enabled)

EXAMPLE:

DE=0 ‘Disable drive

DE=1 ‘Enable drive

RELATED COMMANDS: —

MNEMONIC	FUNCTION	TYPE
DN	Device Name	Setup Variable

DESCRIPTION

The DN Variable stores the device name to be used when the MDrive is to be addressed in party mode operation. The name is only used when party mode communications is being used (PY = 1).

All MDrive system nodes will respond if the name in a command is given as “*”.

When the name is changed it must be saved into the nonvolatile memory if it is to be used in later sessions without being changed again.

See Appendix A: ASCII table for decimal codes.

USAGE

DN=<<char>

UNITS

ASCII Characters

RANGE

a-z, A-Z, 0-9

DEFAULT

!

EXAMPLE:

DN=A ‘Set the device name to the character A

RELATED COMMANDS: PY

MNEMONIC	FUNCTION	TYPE
E	End Program Execution	Program Instruction

DESCRIPTION

Stops the execution of a program.

USAGE

E

EXAMPLE:

PG 100 ‘Start program at line 100

LB J2 ‘Label Program J2

MR 20000 ‘move relative 20000 motor counts

H ‘hold until motion stops

MR -20000 ‘move relative -20000 motor counts

H ‘hold until motion stops

E ‘End program execution

PG ‘exit program mode

RELATED COMMANDS: PG, EX

MNEMONIC	FUNCTION	TYPE
EE	Encoder Enable Flag	Setup Flag

DESCRIPTION

The EE flag enables or disables the optional encoder mode of the MDrive Motion Control.

USAGE

EE= <0/1>

DEFAULT

0 (Disabled)

EXAMPLE:

EE=0 ‘Disable encoder mode

EE=1 ‘Enable encoder mode

RELATED COMMANDS: DB, C2, SF, SM, ST

MNEMONIC	FUNCTION	TYPE
EM	Echo Mode Flag	Setup Flag

DESCRIPTION

The Echo Mode Flag will set the full/half duplex configuration of the RS-485 channel. 0=Full Duplex (default), 1=Half Duplex.

USAGE

EM= <0/1>

DEFAULT

0 (Full Duplex)

EXAMPLE:

EM=0 ‘full duplex mode

EM=1 ‘half duplex mode

RELATED COMMANDS: BD

MNEMONIC	FUNCTION	TYPE
EF	Read-Only Error Flag	Status Flag

DESCRIPTION

The Error flag will indicate whether or not an error condition exists. It is automatically cleared when a new program is executed. The only way to manually clear the EF flag is to read the value of the ER variable or set ER=0

There is an instruction, OE, which allows the user to specify the execution of a subroutine in the program memory when an error occurs. The subroutine might contain instructions to read the ER variable which would clear the EF flag.

USAGE

PR EF

RESPONSE

0 = No Error Exists

1 = Error Condition Exists

EXAMPLE:

PR EF ‘read the state of the error flag

RELATED COMMANDS: ER, OE

MNEMONIC	FUNCTION	TYPE
ER	Error Number Variable	Status Variable

DESCRIPTION

The ER variable indicates the program error code for the most recent error that has occurred in the MDrive Motion Control. The ER variable must be read in order to clear the EF flag.

See Appendix A of this document for a complete listing of MDrive Motion Control Error Codes.

USAGE	RESPONSE
PR ER	<numerical error code>

EXAMPLE:

PR ER 'read the error number

RELATED COMMANDS: EF, OE

MNEMONIC	FUNCTION	TYPE
EX	Execute Program	Program Instruction

DESCRIPTION

Execute program at a specified address or label using a selected trace mode. Used in immediate mode.

There are three modes of program execution.

- Mode 0** Normal execution, is specified by a mode of 0 (or simply leaving the mode blank).
- Mode 1** Trace mode is specified by a mode of 1. This means that the program executes continuously until the program END is encountered, but the instructions are "traced" to the communications port so the user can see what instructions have been executed.
- Mode 2** Single step mode is specified by a mode of 2. In this mode, the user can step through the program using the space bar to execute the next line of the program. The program can be resumed at normal speed in this mode by pressing the enter key.

USAGE	MODES
EX <addr/label>,<mode>	<mode> = 0: run program normally <mode> = 1: run program in trace mode <mode> = 2: run program in single-step mode

EXAMPLE:

EX 127 'execute program at line 127 normally
EX 127,1 'execute program at line 127 in trace mode

RELATED COMMANDS: PG, E

MNEMONIC	FUNCTION	TYPE
HM	Home to Home Switch Variable	Setup Variable

DESCRIPTION

This instruction will find the selected I/O switch. There are four types for this command:

- 1) Speed (S): Specifies the direction and speed that the axis will move until the switch is activated (VM).
- 2) Creep (C): Specifies the direction and speed that the axis will move off the switch until it becomes inactive again (VI).

When HM is executed, the axis moves in the direction specified by the sign of speed at VM. It then creeps off of the switch in the direction specified by the sign of creep at VI. Motion is stopped as soon as the switch becomes deactivated.

USAGE	TYPES
HM=<type>	1: S- C+, 2: S- C-, 3: S+ C-, 4: S+ C+

EXAMPLE:

HM=3 ‘Find home switch at VM in the plus direction, Creep off at VI in the minus direction

RELATED COMMANDS: VM, VI, S1-S4

MNEMONIC	FUNCTION	TYPE
HT	Hold Current Delay Time	Setup Variable

DESCRIPTION

The HT variable sets the delay time in milliseconds between the cessation of motion and when the MDrive Motion Control shifts to the holding current level specified by the HC (Motor Holding Current) variable. The delay time is also effected by the MT (Motor Settling Delay Time) variable in that the total time from motion ceasing to current change is represented by the sum of MT + HT

USAGE	UNITS	RANGE	DEFAULT
HT=<time>	milliseconds	0 to 65000	500

EXAMPLE:

HT=1500 ‘Set hold current delay time to 1.5 seconds

RELATED COMMANDS: HC, MT, RC

MNEMONIC	FUNCTION	TYPE
I1 - I4	Read Input	I/O Variable

DESCRIPTION

This variable will read the state of the specified input 1 - 4. Can be used with PR (Print), BR (Branch) and CI (Call Subroutine) instructions. Can also be used with Ri-R4 and User Variables.

USAGE

- PR I<1-4>
- BR <addr>, I<1-4>=<1/0>
- CL <addr>, I<1-4>=<1/0>

EXAMPLE:

- PR I2 ‘Print the state of Input 2 to the Terminal Screen
- BR 128, I3=1 ‘Conditional branch to program line 128 if Input 3 = 1
- CL 432, I4=0 ‘Call subroutine at line 432 if Input 4 = 0

RELATED COMMANDS: IN, O1-O4, PR, S1-S4

MNEMONIC	FUNCTION	TYPE
I5	Read Analog Input	I/O Variable

DESCRIPTION

This variable will read the value of the voltage seen on the Analog Input. Can be used with PR (Print), BR (Branch) and CL (Call Subroutine) instructions. The value read will be between 0 and 1028.

USAGE

PR I5
 BR <addr/label>, I5=<0 - 1028>
 CL <addr/label>, I5=<0 - 1028>

EXAMPLE:

PR I5 'Print the value of the Analog Input to the Terminal Screen
 BR K1, I5=512 'Branch to Program labled K1 if Analog Input = 512
 CL 432, I5=0 'Call subroutine at line 432 if Analog Input = 0

RELATED COMMANDS: BR, CL, PR

MNEMONIC	FUNCTION	TYPE
I6	Read Encoder Index Mark	I/O Variable

DESCRIPTION

This variable will read the on/off state of the Encoder Index Mark. Can be used with PR (Print), BR (Branch) and CL (Call Subroutine) instructions. The value read will be 0 (off mark) or 1 (on mark).

USAGE

PR I6
 BR <addr/label>, I6=<0/1>
 CL <addr/label>, I6=<0/1>

EXAMPLE:

PR I6 'Print the on/off state of the encoder index mark
 BR K1, I6 'Branch to Program labled K1 if encoder index mark is TRUE
 CL 432, I6=0 'Call subroutine at line 432 if I6=0

RELATED COMMANDS: BR, CL, PR

MNEMONIC	FUNCTION	TYPE
IC	Increment Variable	Program Instruction

DESCRIPTION

The IC instruction will increment the specified variable by one.

USAGE

IC <var>

EXAMPLE:

IC R4 'Increment User Register 4

RELATED COMMANDS: IC

MNEMONIC	FUNCTION	TYPE
L	List Program Space	Instruction

DESCRIPTION

The L instruction will print the contents of program space beginning at the specified address to the end. If no address is specified it will list beginning at line 1.

USAGE

L
L <addr/label>

EXAMPLE:

L 128 ‘display contents of program space beginning at line 128

RELATED COMMANDS: —

MNEMONIC	FUNCTION	TYPE
LB	Label Program/Subroutine	Instruction

DESCRIPTION

The LB, or Label Instruction, allows the user to assign a 2 character name to a program, branch process within a program or subroutine.

The restrictions for this command are:

- 1] A label cannot be named after a MDrive Motion Control Instruction, Variable or Flag.
- 2] The first character must be alpha, the second character may be alpha-numeric.
- 3] A label is limited to two characters.
- 4] A program labeled SU will run on power-up

USAGE

LB <char><char>

EXAMPLE:

PG 100 ‘start program at adress 100
LB J0 ‘Label program J0

RELATED COMMANDS: BR, CL, EX, TI, TP, L, CP

MNEMONIC	FUNCTION	TYPE
LK	Lock User Program	Setup Flag

DESCRIPTION

This flag allows the user to lock the program from being listed or modified. It can only be reset by clearing the entire program space: CP (no address). If CP addr, L (addr), PG addr entered then error 44 (Program Locked) will be set and nothing else will happen.

To clear LK, don't save (S) then do a Ctrl-C or Cycle Power and the LK will be reset to previous unlocked state. (Program is automatically store in NVM as it is entered.) Or you may clear program (CP). This will clear the program and reset LK to 0 in NVM as well as in local ram.

USAGE

LK= <0/1>

DEFAULT

0 (Disabled)

RELATED COMMANDS: CP, L

MNEMONIC	FUNCTION	TYPE
MA	Move To Absolute Position	Motion Instruction

DESCRIPTION

Set mode for absolute move and move to an absolute position. MD (Current Mode) will be set to MA.

USAGE

MA <±pos>

UNITS

motor counts

EXAMPLE:

MA 51200 'move motor to absolute position 51200 in positive direction

MA -51200 'move motor to absolute position 51200 in negative direction

RELATED COMMANDS: MD, MR, MS, P

MNEMONIC	FUNCTION	TYPE
MD	Motion Mode	Motion Instruction

DESCRIPTION

Indicates what the last motion command was, so that when just a number is entered, then it will read MD to define the new motion.

USAGE

MD

EXAMPLE:

MA 200000 'move absolute 200000 steps, set current mode to MA

-200000 'move absolute -200000 steps

MR 1000000 'move relative 1000000 steps, set current mode to MR

-1000000 'move relative -1000000 steps

SL 20000 'slew 20000 steps/sec. set current mode to SL

-10000 'slew 10000 steps/sec in minus direction

PR MD return current mode setting

RELATED COMMANDS: MD, MR, MS, P, PR, SL

MNEMONIC	FUNCTION	TYPE
MR	Move To Relative Position	Motion Instruction

DESCRIPTION

Set mode for relative move and move a relative distance. MD (Current Mode) will be set to MR.

USAGE

MR <±distances>

UNITS

motor counts

EXAMPLE:

MR 200000 'move motor to 200000 motor counts positive direction

MR -50000 'move motor to 50000 motor counts in a negative direction

RELATED COMMANDS: MD, MA, MS, P

MNEMONIC

MS

FUNCTION

Microstep Resolution

TYPE

Motion Variable

DESCRIPTION

The MS variable controls the microstep resolution of the MDrive Motion Control. There are 14 parameters that can be used with this variable, 8 binary and 6 decimal. The table below illustrates the parameter settings and their associated resolutions for the 1.8° stepping motor used with the MDrive Motion Control.

The MS parameters given in the table below are the only valid parameters that will be accepted by the MDrive.

USAGE

MS=<parameter>

DEFAULT

256

EXAMPLE:

MS=4 'Set Microstep Resolution to 4 Microsteps/Step (400 Steps/Rev)

MS=50 'Set Microstep Resolution to 50 Microsteps/Step (10000 Steps/Rev)

PR MS 'Print the MS setting to the terminal

Microstep Resolution Settings (MS)	
MS= (Microsteps/Step)	Steps/Rev
Binary Microstep Resolution Settings	
2	400
4	800
8	1,600
16	3,200
32	6,400
64	12,800
128	25,600
256	51,200
Decimal Microstep Resolution Settings	
5	1,000
10	2,000
25	5,000
50	10,000
125	25,000
250	50,000

Table 2.6: Microstep Resolution Settings

MNEMONIC	FUNCTION	TYPE
MT	Motor Settling Delay Time	Motion Variable

DESCRIPTION

Specifies the motor settling delay time in milliseconds. MT allows the motor to settle following a move. This is the time between moves if consecutive motions are executed.

USAGE	UNITS	RANGE	DEFAULT
MT=<time>	milliseconds	0 to 65000	0

EXAMPLE:

MT=50 'Set motor settling delay time to 50 milliseconds

RELATED COMMANDS: HC, HT, RC

MNEMONIC	FUNCTION	TYPE
O1 - O4	Set/Print Output Logic State	I/O Variable

DESCRIPTION

This variable will set the logic state of the specified output to 1 or 0. When used with the PR (Print) instruction it will print the state of the specified output to the terminal screen.

The value of the bit state will be dependant on the active (low/high) state of the input.

USAGE

O<1-4>=<0/1>
PR O<1-4>

EXAMPLE:

O4=1 'Set Output 4 to 1
PR O2 'Print the state of Output 2 to the Terminal Screen

RELATED COMMANDS: OT, I1-I4, PR, S1-S4

MNEMONIC	FUNCTION	TYPE
OE	On Error Handler	Instruction

DESCRIPTION

When an error occurs in a program or due to an immediate command, the specified subroutine is called. If a program was running when the fault occurs, once the error routine completes, program execution continues with the instruction after the one that caused the error. A program need not be running for the subroutine specified by OE to run.

The ON ERROR function is disabled by setting the address parameter to 0 or resetting the MDrive Motion Control.

USAGE

OE <address>

EXAMPLE:

'the following subroutine will set an output high upon an error
PG 100 'Start sub at address 100
OE E1 'On Error go to E1
LB E1 'label subroutine E1
O3=1 'Set Output 3 to Logic 1
RT 'Return from subroutine
E 'End program
PG 'Return to immediate mode

RELATED COMMANDS: EF, ER

MNEMONIC	FUNCTION	TYPE
OT	Set Outputs 1-4 As 1 Value	I/O Variable

DESCRIPTION

The OT variable allows the user to set Outputs 1-4 as one 4 bit binary value. The value is entered in decimal, with a range of 0-15 and will display in binary where Output 1 will be the LSB and Output 4 will be the MSB.

Example: OT=12

Output 4 = 1

Output 3 = 1

Output 2 = 0

Output 1 = 0

USAGE

OT=<0-15>

PR OT

EXAMPLE:

OT=7 'Set outputs 1-4 to O1=1, O2=1, O3=1, O4=0

RELATED COMMANDS: I1-I4, S1-S4

MNEMONIC	FUNCTION	TYPE
P	Set/Print Position Counter	Instruction

DESCRIPTION

This instruction is used to set or print the value of the MDrive Motion Control position counter. The position will read in Motor Counts from C1 (Counter 1) by default, if encoder functions are enabled, the position counter will read in Encoder Counts from C2 (Counter 2).

The main difference in the relationship of the two counters is that where C1 is variable, the value of each count in terms of distance moved is based upon the MS, or microstep resolution setting, C2 will always be 2048 counts per motor revolution, regardless of the microstep resolution setting.

Modifying P in essence changes the frame of reference for the axis. P will probably be set once during system set up to reference or "home" the system.

USAGE

P <±position>

PR P

UNITS

Steps

RANGE

-2147483648 to 2147483647

EXAMPLE:

P=0 'Clear position counter, set to 0

PR P 'Print the state of the position counter

RELATED COMMANDS: C1, C2

MNEMONIC	FUNCTION	TYPE
PM	Position Maintenance Enable	Setup Flag

DESCRIPTION

This flag will enable the position maintenance functions of an MDrive Motion Control with encoder. The position maintenance velocity will be at the setting for VI (Initial Velocity).

USAGE

PM= <0/1>

DEFAULT

0 (Disabled)

EXAMPLE:

PM=0 ‘Position Maintenance Disabled (Default)
 PM=1 ‘Position Maintenance Enabled

RELATED COMMANDS: VI

MNEMONIC	FUNCTION	TYPE
PG	Enter/Exit Program Mode	Program Instruction

DESCRIPTION

When starting program mode, you must specify at what address to enter the program instructions in the program space. Simply type “PG” again when you have finished entering your program commands to go back to immediate mode.

While in program mode, leading tabs, spaces and blank lines are ignored. This allows the user to format a text file for readability, and then download the program to the MDrive by transferring the text file in a program such as IMSTerminal or Hyperterminal. The example given below could be stored in a text file and downloaded. The lines preceded by an apostrophe (‘) are comments and will be ignored by the MDrive Motion Control.

USAGE

PG <address>

EXAMPLE:

PG 100 ‘Enter program mode, start program at address 100
 *****PROGRAM*****
 E ‘End program
 PG ‘Exit program, return to immediate mode

RELATED COMMANDS: E,

MNEMONIC	FUNCTION	TYPE
PR	Print Selected Data/Text	Instruction

DESCRIPTION

This instruction is used to output text and parameter value(s) to the host PC. Text should be enclosed in quotation marks while parameters (variables and flags) should not. Text strings and parameters which are to be output by the same PR instruction should be separated by commas. The information being output is followed by a carriage return and line feed unless a semicolon (;) is included at the end of the PR instruction to indicate that the cursor should remain on the same line.

It is important to note that the receive buffer for the MDrive Motion Control is 64 characters, this includes the PR instruction itself, any spaces, text characters, etc. If the buffer length is exceeded ASCII code “OxFF” will echo to the terminal screen.

USAGE

PR <data/text>

EXAMPLE:

PR “Position =”, P ‘print axis position, 18 characters used
 ‘the terminal will display: Position = 1234567

RELATED COMMANDS: —

MNEMONIC	FUNCTION	TYPE
PS	Pause Program Instruction	Instruction

DESCRIPTION

This instruction is used to pause an executing program. Immediate mode instructions are allowed while a program is in a paused state. To resume the program the RS instruction is used.

USAGE

PS

EXAMPLE:

PS

RELATED COMMANDS: RS

MNEMONIC	FUNCTION	TYPE
PY	Party Mode Enable Flag	Setup Flag

DESCRIPTION

The party flag will be set to 1 if the MDrive Motion Control is being used in a multidrop system.

When party mode is enabled each MDrive in the system must be addressed using the device name, specified by the DN instruction. This name will precede any command given to a specified unit in the system. By default the DN assigned at the factory is the exclamation character (!).

The global name is the asterisk character (*). Commands preceded by this character will be recognized by every MDrive in the system.

USAGE

PY= <0/1>

DEFAULT

0 (Disabled)

EXAMPLES:

PY=0 ‘Party Mode Disabled (Default)

PY=1 ‘Party Mode Enabled

RELATED COMMANDS: DN

MNEMONIC	FUNCTION	TYPE
R1 - R4	User Registers	User Variable

DESCRIPTION

The MDrive Motion Control has four 32 bit user registers to contain numerical data. These registers may contain up to 11 digits including the sign and may be used to store and retrieve data to set variables, perform math functions, store and retrieve moves and set conditions for branches and subroutine calls.

USAGE	RANGE	DEFAULT
R<x>=<data>	-2147483647 to 2147483647	0

EXAMPLES:

```

R1=50000      'Set Register 1 to 50000
'Subroutine using a register value to perform a math function that will display axis position in revolutions rather than motor steps
'****variable setup****
MS=256       'set resolution to 256 microsteps/step
P=0          'set position counter to 0
R1=51200/1   '51200 steps = 1 rev
'****Program Content****
MR R1        'move relative 102400 steps
H            'Hold execution until motion stops
CL 348       'call subroutine at address 348
'*****Sub at address 348*****
R2=P        'set Register 2 equal to the position counter
R3=R2/R1    'set Register 3 equal to R2/R1
PR "Position = ", R3, "Revolutions";
H 60000     'hold for 1 minute
RT          'return to prog

```

RELATED COMMANDS: —

MNEMONIC	FUNCTION	TYPE
RC	Run Current	Setup Variable

DESCRIPTION

This variable defines the motor run current in percent.

USAGE	UNITS	RANGE	DEFAULT
RC=<percent>	Percent	1to 100	25

EXAMPLE:

```
RC=75      'Set motor run current to 75%
```

RELATED COMMAND: HC

MNEMONIC	FUNCTION	TYPE
RS	Resume Program Instruction	Instruction

DESCRIPTION

This instruction is used to resume a program that has been paused using the PS instruction.

USAGE

RS

EXAMPLE:

RS

RELATED COMMANDS: PS

MNEMONIC	FUNCTION	TYPE
RT	Return From Subroutine	Instruction

DESCRIPTION

This instruction defines the end of a subroutine. This instruction is required and will be the final instruction in the subroutine executed by the CL instruction. When used, it will return to the program address immediately following the CL instruction which executed the subroutine.

USAGE

RT

EXAMPLE:

```

****Program****
      PG100      'enter program mode at address 100
100    MR 51200  'move relative 51200
105    H         'suspend prog. execution until motion completes
109    CL 238    'Call subroutine at address 238

      238    OI=1      'set output 1 to 1
      241    RT         'return from subroutine
  
```

RELATED COMMANDS: CL

MNEMONIC	FUNCTION	TYPE
S	Save to EEPROM	Instruction

DESCRIPTION

Saves all variables and flags currently in working memory (RAM) to nonvolatile memory (NVM). The previous values in NVM are completely overwritten with the new values.

When the user modifies variables and flags, they are changed in working memory (RAM) only. If the SAVE instruction is not executed before power is removed from the control module, all modifications to variables & flags since the last SAVE will be lost.

USAGE

S

RELATED COMMANDS: —

MNEMONIC	FUNCTION	TYPE
S1 - S4	Set/Print I/O Point Type/Active State	I/O Instruction

DESCRIPTION

This instruction is used to setup the I/O type and active states for I/O points 1 - 4. Each of MDrive Motion Control I/O points 1-4 may be programmed as either general purpose inputs and outputs, or to one of nine dedicated input functions or one of two dedicated output functions.

When programmed as inputs, these points will be sinking and may be programmed such that they are active when pulled to ground, or active when left floating. By default each point is configured as a general purpose input, active when LOW.

There are two parameters attached to this instruction: the type specifies the function of the I/O point. The second parameter sets the active state, which defines the point as LOW or HIGH TRUE.

I/O FUNCTION	TYPE	ACTIVE STATE	PARAMETER
INPUTS			
General Purpose Input	0	LOW = TRUE	0
Home Input	1	HIGH = TRUE	1
Limit + Input	2		
Limit - Input	3		
G0 Input	4		
Soft Stop Input	5		
Pause Input	6		
Jog + Input	7		
Jog - Input	8		
OUTPUTS			
General Purpose Output	16		
Moving Output	17		
Fault Output	18		
Stall	19		

USAGE	DEFAULT
S<1-4>=<type>,<active>	<type>=0, <active>=0

EXAMPLE:

S1=2,0 'set i/o point 1 to a limit + function, active when LOW

S4=17,1 'set i/o point 4 as moving output, active when HIGH

RELATED COMMANDS: I1-4, IN, O1-4, OT

MNEMONIC	FUNCTION	TYPE
S5	Set/Print I/O Point 5	I/O Instruction

DESCRIPTION

This I/O point differs from I/O points 1-4 in that it is factory configured as a 0 - 5 V Analog Input with 10 bit A/D resolution.

I/O FUNCTION	TYPE
0-5V Analog Input	9
4-20 mA Analog Input	10

RELATED COMMANDS: I5, JE

MNEMONIC	FUNCTION	TYPE
SF	Stall Factor Variable	Encoder Variable

DESCRIPTION

If the encoder is enabled (EE = 1) and the encoder differs from the motor by more than the specified factor, a STALL is indicated. If SM is set to 0, then the motor will be stopped when a STALL is detected.

USAGE	UNITS	RANGE	DEFAULT
SF=<counts>	Encoder counts	0 to 65000	10

EXAMPLE:

SF=20 'Set the stall factor to twenty counts. If the motor falls behind by more than 20 encoder counts a stall is detected.

RELATED COMMANDS: EE, SM, ST

MNEMONIC	FUNCTION	TYPE
SL	Slew Axis Instruction	Motion Instruction

DESCRIPTION

The SL instruction will slew the axis at the specified velocity in counts per second. The axis will accelerate at the rate specified by the A (Acceleration) variable.

Note that the maximum slew velocity is independant of the maximum velocity specified by the VM variable. If a slew is commanded at a velocity greater than the setting of VM, the axis will accelerate to that velocity regardless of the setting of VM.

USAGE	UNITS	RANGE
SL <±velocity>	± Counts per sec	±5000000

EXAMPLE:

SL=20000 'slew the axis at 20000 counts/sec

RELATED COMMANDS: A, D, MS, MR

MNEMONIC	FUNCTION	TYPE
SM	Stall Detection Mode Variable	Encoder Variable

DESCRIPTION

The SM variable specifies the action which will be taken by the MDrive Motion Control when a stall is detected. When set to 0 (default) the motion will be stopped upon a stall detection. When SM=1, the motor will continue to move. In either case ST (Stall Flag) will be set.

USAGE	DEFAULT
SM = <0/1>	0 (Stop Motor)

EXAMPLE:

SM=0 'stop motor when a stall is detected

SM=1 'do not stop motor upon a stall

RELATED COMMANDS: EE, SF, ST

MNEMONIC	FUNCTION	TYPE
ST	Read Only Stall Flag	Encoder Flag

DESCRIPTION

The ST flag will be set to 1 when a stall is detected. It will be cleared upon execution of another motion command.

USAGE

PR ST
 BR <addr>, ST=1
 CL <addr>, ST=1

EXAMPLE RESPONSE:

ST=0 'motor not stalled
 ST=1 'motor stalled

RELATED COMMANDS: EE, SF, ST

MNEMONIC	FUNCTION	TYPE
TE	Trip Enable Flag	Setup Flag

DESCRIPTION

This flag will enable or disable specified trip functions.

TE=0	TI Disabled	TP Disabled
TE=1	TI Enabled	TP Disabled
TE=2	TI Disabled	TP Enabled
TE=3	TI Enabled	TP Enabled

USAGE

	DEFAULT
TE= <1-4>	0 (Trips Disabled)

EXAMPLE:

TE=1 'Enable trip on input functions

RELATED COMMANDS: I1-I4, P, S1-S4, TI, TP

MNEMONIC	FUNCTION	TYPE
TI	Trip on Input	Variable

DESCRIPTION

Sets up an input event (trip) for the specified input. There are two parameters for the TI variable. The first specifies the address of the subroutine that should be executed when the input goes to true. The second specifies which input line to monitor.

USAGE

TI=<input>,<addr/label>

EXAMPLE:

TI=2,K1 'execute subroutine labeled K1 when input 2 is active.

RELATED COMMANDS: I1-4, S1-4, TP

MNEMONIC	FUNCTION	TYPE
TP	Trip on Position	Variable

DESCRIPTION

Sets up a position event (trip) for the specified position. There are two parameters for the TP variable. The first specifies the address of the subroutine that should be executed when the position is detected. The second specifies the position which will cause the event.

USAGE

TP=<position>,<addr/label>

EXAMPLE:

TP=200000,300 'execute subroutine at address 300 when at position 200000

RELATED COMMANDS: P, TI, PC

MNEMONIC	FUNCTION	TYPE
UG	Upgrade Firmware	Instruction

DESCRIPTION

Upgrade Firmware Instruction. Upgrade code is 2956102. This will put the MDrive in Upgrade Mode, once set the firmware MUST be upgraded.

USAGE

UG 2956102

RELATED COMMANDS: —

MNEMONIC	FUNCTION	TYPE
UV	Read User Variables	Variable

DESCRIPTION

Read User Variables is used with the PR (Print) Instruction to read the value of all user variables

USAGE

PR UV

RELATED COMMANDS: , PR, VA

MNEMONIC	FUNCTION	TYPE
V	Read Only Velocity Variable	Motion Variable

DESCRIPTION

The velocity variable is used in conjunction with the PR (print) instruction to read the current velocity of the axis in counts per second. This variable can also be used with the BR and CL instructions to set a condition based upon a velocity. This variable can also be used in conjunction with the user registers to compute another velocity.

USAGE

PR V
 BR <addr>, V=<counts/sec>
 CL <addr>, V=<counts/sec>

UNITS

Counts per Second

RELATED COMMANDS: VI, VM

MNEMONIC	FUNCTION	TYPE
VA	Create User Variable Name	Instruction

DESCRIPTION

The VA instruction allows the user to assign a 2 character name to a user defined variable.

The restrictions for this command are:

- 1] A variable cannot be named after a MDrive Motion Control Instruction, Variable or Flag.
- 2] The first character must be alpha, the second character may be alpha-numeric.
- 3] A variable is limited to two characters.

USAGE

VA <char><char>=<value>

EXAMPLE:

VA P2 'create user var P2
 P2=20000 'set P2 to 20000

RELATED COMMANDS: UV

MNEMONIC	FUNCTION	TYPE
VI	Initial Velocity Variable	Motion Variable

DESCRIPTION

Initial velocity for all motion commands. The factory default value is 1000 clock pulses per second.

The initial velocity for a stepper should be set to avoid the low speed resonance frequency and must be set lower than the pull in torque of the motor. It must also be set to a value lower than VM (Max. Velocity).

USAGE

VI=<velocity>

UNITS

Counts per sec

RANGE

1 to 5000000

DEFAULT

1000

EXAMPLE:

VI=2000 'set initial velocity to 2000 counts per second

RELATED COMMANDS: VM

MNEMONIC	FUNCTION	TYPE
VM	Maximum Velocity Variable	Motion Variable

DESCRIPTION

The VM variable specifies the maximum velocity in counts per second that the axis will reach during a move command

USAGE	UNITS	RANGE	DEFAULT
VM=<velocity>	Counts per sec	1 to 5000000	768000

EXAMPLE:

VM=51200 'set max velocity to 51200 counts per second

RELATED COMMANDS: VM

MNEMONIC	FUNCTION	TYPE
VR	Read Only Firmware Version	Factory Variable

DESCRIPTION

This variable is used in conjunction with the PR instruction to read the version of the firmware installed at the factory. If the Version number is followed by an E, the Mdrive is an Encoder Version. An I will indicate and Index version. Blank will indicate no options.

USAGE

PR VR

RELATED COMMANDS: —

Appendix A

ASCII TABLE

<u>Dec</u>	<u>Hex</u>	<u>Char</u>	<u>Dec</u>	<u>Hex</u>	<u>Char</u>	<u>Dec</u>	<u>Hex</u>	<u>Char</u>	<u>Dec</u>	<u>Hex</u>	<u>Char</u>
0	0	NUL	32	20		64	40	@	96	60	`
1	1	SOH	33	21	!	65	41	A	97	61	a
2	2	STX	34	22	"	66	42	B	98	62	b
3	3	ETX	35	23	#	67	43	C	99	63	c
4	4	EOT	36	24	\$	68	44	D	100	64	d
5	5	ENQ	37	25	%	69	45	E	101	65	e
6	6	ACK	38	26	&	70	46	F	102	66	f
7	7	BEL	39	27	'	71	47	G	103	67	g
8	8	BS	40	28	(72	48	H	104	68	h
9	9	TAB	41	29)	73	49	I	105	69	i
10	A	LF	42	2A	*	74	4A	J	106	6A	j
11	B	VT	43	2B	+	75	4B	K	107	6B	k
12	C	FF	44	2C	´	76	4C	L	108	6C	l
13	D	CR	45	2D	-	77	4D	M	109	6D	m
14	E	SO	46	2E	.	78	4E	N	110	6E	n
15	F	SI	47	2F	/	79	4F	O	111	6F	o
16	10	DLE	48	30	0	80	50	P	112	70	p
17	11	DC1	49	31	1	81	51	Q	113	71	q
18	12	DC2	50	32	2	82	52	R	114	72	r
19	13	DC3	51	33	3	83	53	S	115	73	s
20	14	DC4	52	34	4	84	54	T	116	74	t
21	15	NAK	53	35	5	85	55	U	117	75	u
22	16	SYN	54	36	6	86	56	V	118	76	v
23	17	ETB	55	37	7	87	57	W	119	77	w
24	18	CAN	56	38	8	88	58	X	120	78	x
25	19	EM	57	39	9	89	59	Y	121	79	y
26	1A	SUB	58	3A	:	90	5A	Z	122	7A	z
27	1B	ESC	59	3B	;	91	5B	[123	7B	{
28	1C	FS	60	3C	<	92	5C	\	124	7C	
29	1D	GS	61	3D	=	93	5D]	125	7D	}
30	1E	RS	62	3E	>	94	5E	^	126	7E	~
31	1F	US	63	3F	?	95	5F	_	127	7F	DEL

Appendix B

Error Codes

Error Code	Fault
0	No Error
I/O Errors	
1	I/O1 Fault
2	I/O2 Fault
3	I/O3 Fault
4	I/O4 Fault
5	I/O5 Fault
6	An I/O is already set to this type.
7	Tried to set an Input or defined I/O.
8	Tried to set an I/O to an incorrect I/O type.
9	Tried to write to I/O set as input or is "TYPED".
10	Illegal I/O number.
Data Errors	
20	Tried to set unknown variable or flag.
21	Tried to set an incorrect value.
22	VI set greater than or equal to VM.
23	VM is set less than or equal to VI.
24	Illegal data entered.
25	Variable or flag is read only.
26	Variable or flag is not allowed to be incremented or decremented.
27	Trip not defined.
28	Trying to redefine a program label or variable.
29	Trying to redefine an embedded command or variable.
30	Unknown label or user variable.
31	Program label or user variable table is full.
Program Errors	
40	Program not running.
41	Program running.
42	Illegal program address.
43	Tried to overflow program stack.
Communications Errors	
60	Tried to enter unknown command.
61	Trying to set illegal BAUD rate.
Motion Errors	
80	HOME switch not defined.
81	HOME type not defined.
82	Went to both LIMITS and did not find home
83	Reached positive LIMIT switch.
84	Reached minus LIMIT switch.
85	MA or MR not allowed while in motion.
86	Stall detected.

TWENTY-FOUR MONTH LIMITED WARRANTY

Intelligent Motion Systems, Inc., warrants its products against defects in materials and workmanship for a period of 24 months from receipt by the end-user. During the warranty period, IMS will either, at its option, repair or replace Products which prove to be defective.

EXCLUSIONS

The above warranty shall not apply to defects resulting from: improper or inadequate handling by customer; improper or inadequate customer wiring; unauthorized modification or misuse; or operation outside of the electrical and/or environmental specifications for the Product.

OBTAINING WARRANTY SERVICE

To obtain warranty service, a returned material authorization number (RMA) must be obtained from customer service at (860) 295-6102 before returning product for service. Customer shall prepay shipping charges for Products returned to IMS for warranty service and IMS shall pay for return of Products to customer. However, customer shall pay all shipping charges, duties and taxes for Products returned to IMS from another country.

WARRANTY LIMITATIONS

IMS makes no other warranty, either expressed or implied, with respect to the Product. IMS specifically disclaims the implied warranties of merchantability and fitness for a particular purpose. Some jurisdictions do not allow limitations on how long an implied warranty lasts, so the above limitation or exclusion may not apply to you. However, any implied warranty of merchantability or fitness is limited to the 24-month duration of this written warranty.

EXCLUSIVE REMEDIES

If your Product should fail during the warranty period, call customer service at (860) 295-6102 to obtain a returned material authorization number (RMA) before returning product for service. Please include a written description of the problem along with contact name and address. Send failed product to: Intelligent Motion Systems, Inc., 370 N. Main St. Marlborough, Connecticut 06447. Also enclose information regarding the circumstances prior to Product failure.



P.O. Box 457, 370 N. Main Street
Marlborough, CT 06447 U.S.A.

Phone: 860/295-6102
Fax: 860/295-6107
Email: info@imshome.com
Home Page: www.imshome.com

WESTERN REGION
IMS Motors Division and
Western U.S. Technical Support
105 Copperwood Way, Suite H
Oceanside, CA 92054
Phone: 760/966-3162
Fax: 760/966-3165
E-mail Motors Division:
motors@imshome.com
E-mail Western Tech Support:
wtech@imshome.com
Western U.S. Sales Management
Phone: 949/707-0156
Fax: 949/707-0157
Email: wsales@imshome.com

IMS EUROPE
Administration
Hahnstrasse 10
VS-Schwenningen
Germany D-78054
Phone: +49/7720/94138-0
Fax: +49/7720/94138-2
European Sales Management
4 Quai Des Etroits
69005 Lyon, France
Phone: +33/4 7256 5113
Fax: +33/4 7838 1537
Email: bmartinez@imshome.com
Sales/Tech Support for Germany
Phone: +49/35205/4587-8
Fax: +49/35205/4587-9
Email: hruhland@imshome.com